

Next Fit MT

CE

NX FIT MT AUTOTRQ 3017 SH BD

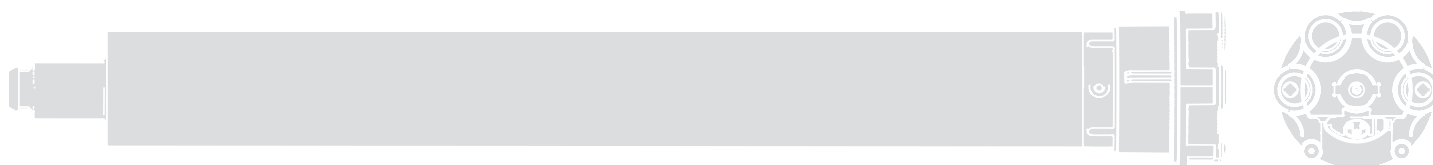

Tubular Motor

EN - Instructions and warnings for installation and use

Nice

GENERAL WARNINGS: SAFETY - INSTALLATION - USE (original instructions in Italian)

ATTENTION Important safety instructions. Follow all instructions as improper installation may cause serious damage
ATTENTION Important safety instructions. It is important for you to comply with these instructions for your own and other people's safety. Keep these instructions

- Before commencing the installation, check the "Technical characteristics" (in this manual), in particular whether this product is suitable for automating your guided part. If it is not suitable, DO NOT continue with the installation
- The product cannot be used before it has been commissioned as specified in the chapter on "Testing and commissioning"

ATTENTION According to the most recent European legislation, the implementation of an automation system must comply with the harmonised standards provided by the Machinery Directive in force, which enables declaration of the presumed conformity of the automation. Taking this into account, all operations regarding connection to the electricity grid, as well as product testing, commissioning and maintenance, must be performed exclusively by a qualified and skilled technician!

- Before proceeding with the installation of the product, check that all the materials are in good working order and suited to the intended applications
- This product is not intended to be used by persons (including children) whose physical, sensory or mental capacities are reduced, or who lack the necessary experience or skill
- Children must not play with the appliance
- Do not allow children to play with the fixed control devices of the product. Keep the remote controls away from children

ATTENTION In order to avoid any danger from inadvertent resetting of the thermal cut-off device, this appliance must not be powered through an external switching device, such as a timer, or connected to a supply that is regularly powered or switched off by the circuit

- Provide a disconnection device (not supplied) in the plant's power supply grid, with a contact opening distance permitting complete disconnection under the conditions dictated by overvoltage category III
- Handle the product with care during installation, taking care to avoid crushing, denting or dropping it, or allowing contact with liquids of any kind. Keep the product away from sources of heat and naked flames. Failure to observe the above can damage the product, and increase the risk of danger or malfunction. Should this happen, stop installation immediately and contact Customer Service
- The manufacturer assumes no liability for damage to property, items or persons resulting from non-compliance with the assembly instructions. In such cases the warranty for material defects is excluded
- The weighted sound pressure level of the emission A is lower than 70 dB(A)
- Cleaning and maintenance to be carried out by the user must not be carried out by unsupervised children
- Before working on the system (maintenance, cleaning), always disconnect the product from the mains power supply
- Check the system periodically, in particular all cables, springs and supports to detect possible imbalances, signs of wear or damage. Do not use, if repairs or adjustments are necessary, since installation failure or an incorrectly balanced automation may cause injury
- The packing materials of the product must be disposed of in compliance with local regulations
- There must be at least 0.4 m between the driven parts and any fixed elements
- The wording on the tubular motors can be covered after assembly
- Motor with **removable** power cable and dedicated connector: if the power cable is damaged, it **must be replaced** by the manufacturer or by the latter's technical assistance service, or by a similarly qualified person, in order to prevent any type of risk.
- Be careful with moving roller blinds and keep away from them until they have lowered fully
- Do not activate the awning when maintenance activities – such as window cleaning – are being carried out nearby
- Disconnect the awning from the power supply when maintenance activities such as window cleaning are being carried out nearby. Warning for 'shades with automatic control'

INSTALLATION WARNINGS

- Prior to installing the drive motor, remove any unnecessary cables and disable any appliance not required for motorised operation
- Install the manoeuvring assembly for manual release at a height below 1.8 m
NOTE: if removable, the manoeuvring assembly must be kept close to the door
- Make sure that the control devices are kept far from moving parts but nonetheless in a visible position.
The manoeuvring assembly of a switch kept manually closed must be located in a position visible from the guided part but far from moving parts. It must be installed at a minimum height of 1.5 m
- The fixed control devices must be installed in a visible position
- For drive motors that allow for accessing unprotected moving parts once they have been installed, such parts must be installed 2.5 m above the floor or other surface from which they can be accessed

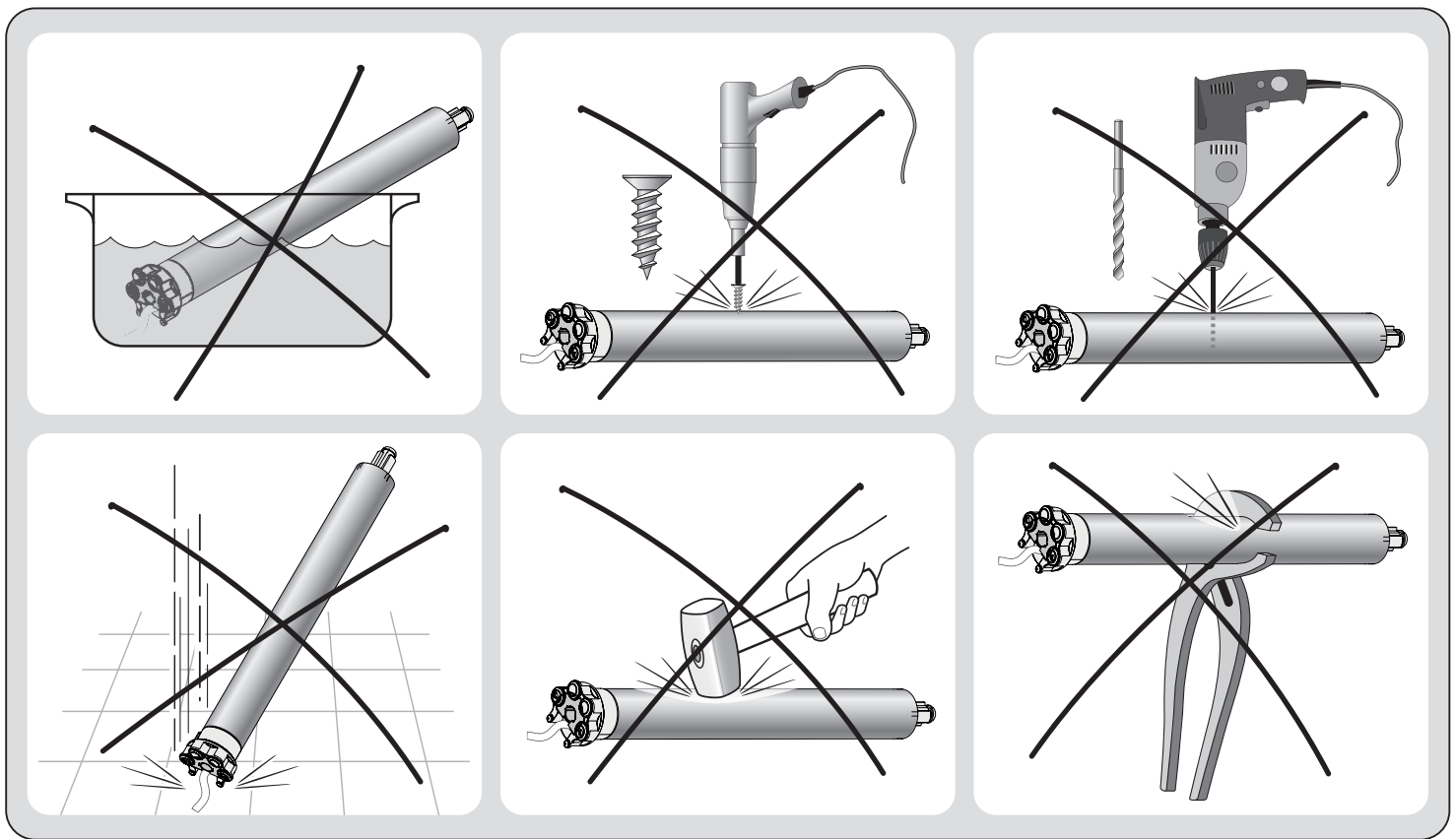

1 PRODUCT DESCRIPTION AND INTENDED USE

This product is a tubular motor for automating of various types of awnings. **Do not use it for any other purpose! The manufacturer declines all liability for damage resulting from improper use of the product or any other use than that specified in this manual.**

The product has the following functional characteristics:

- it is mains powered (see the motor's nameplate ratings);
- it installs inside the winding roller; the part of the motor that protrudes from the roller (electronic head) mounts to the ceiling or wall with brackets (not included);
- it has a built-in radio receiver and control unit with encoder technology that electronically controls the movement and precision of the limit switches;
- can be configured for both ONE-WAY and TWO-WAY transmission. Nice's new two-way radio protocol enables communication in both directions between the transmitter and receiver, as does the mesh network which can connect to any Nice automation within radio range. The transmitter signal confirms that the control has been received correctly and allows the position of the automation to be controlled at all times. Wireless technology makes even initial programming simple and user-friendly.
- it is compatible with all Nice control electronics using the NRC radio system (transmitters and climate sensors, the latter can only be used if the motor is configured for operation in ONE-WAY mode);
- it can be controlled with a radio transmitter or cabled wall-mounted button panel (see **fig. 1**);
- it can move the awnings, blind or shutter up or down; stop it at the upper limit switch, the lower limit switch or various intermediate positions (up to 30 if the motor is configured for operating in ONE-WAY mode or up to 6 if it is configured for operating in TWO-WAY mode);
- is equipped with a "thermal protection device" which, in case of extended use, protect the motor against excessive overheating by limiting the motor speed to the minimum speed; in this way, the continuous usage time increases, allowing extended use (until the thermal protection device intervenes);
- it is available in several versions, each with a certain motor torque (power).

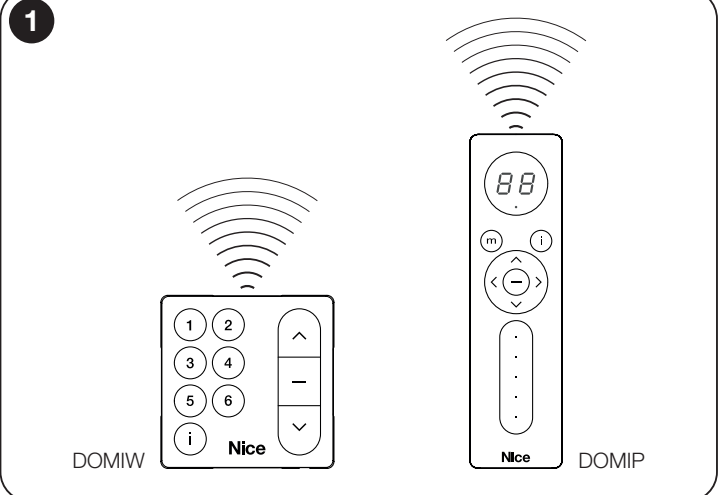

2 INSTALLATION OF THE MOTOR AND THE ACCESSORIES

2.1 - Preliminary checks before installation and limitations on use

- Check the condition of the product right after unpacking it.
- This product is available in several version, each with a specific motor torque. Each version is designed to drive awnings of a certain size and weight. Therefore, before installation make sure the product's motor torque, rotation speed and operation time are suitable for automating your awning (see the "Guide to Selection" section, in the Nice Product Catalogue – www.niceforyou.com). In particular, **do not install the product if its motor torque is lower than that needed to move your awning.**
- Check the diameter of the winding roller. This must be chosen according to the motor torque, as follows:
 - for motors that are size "M" ($\varnothing = 45$ mm) and have a torque of up to 35 Nm (included, the minimum inside diameter of the winding roller must be 52 mm).
- Before automating a awning, check that there is enough free space in front of it for it to be completely opened.
- If the motor is to be installed outdoors, adequate protection against atmospheric agents must be guaranteed.

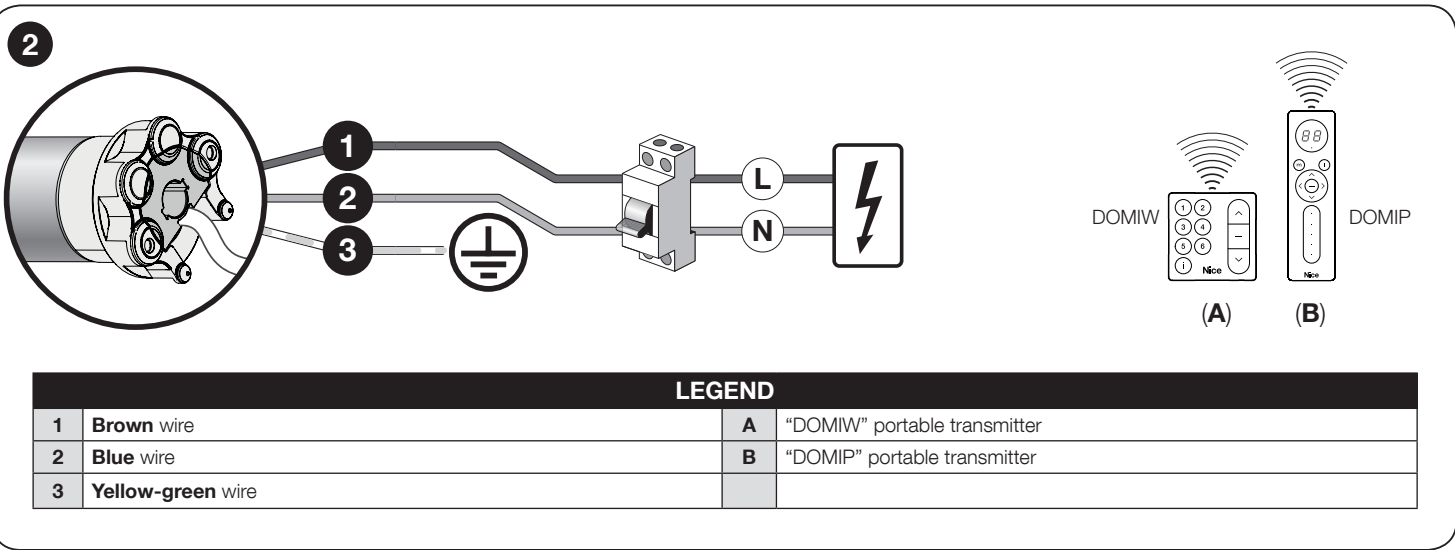

2.2 - Assembling and installing the tubular motor

Caution! – Read the safety warnings before proceeding. Incorrect installation could cause severe physical injury.

To assemble and install the motor, refer to **fig. 3**. Moreover, consult the Nice product catalogue or go to www.niceforyou.com to choose the crown of the limit switch (**fig. 3-a**), the drag wheel (**fig. 3-b**), and the motor fastening bracket (**fig. 3-f**).

2.3 - Installation of accessories (optional)

After installing the motor, install the accessories, if required. In order to identify those that are compatible and choose the models desired, see the Nice product catalogue, also viewable at www.niceforyou.com. **Fig. 2** shows the type of accessories that are compatible and their connection to the motor (all of these are options and not included in the package).

4 PROGRAMMING AND ADJUSTMENTS

4.1 - TWO-WAY and ONE-WAY operation

The motor can operate with both TWO-WAY and ONE-WAY transmission. The transmission mode is determined by the first transmitter paired with the motor (ONE-WAY or TWO-WAY).

WARNING: if the motor is new (and does not have any remote control memorised), at the start-up run one of the memorisation procedures for the first transmitter described at points B.1 motor configured for ONE-WAY communication, A.1 motor configured for TWO-WAY communication, or C.1 motor configured for ONE-WAY communication and OLD generation transmitter lacking the PRG and ESC buttons. In this way, the motor will be configured in the TWO-WAY mode (and thus will be able to accept all two-way transmitters) or ONE-WAY mode (and thus will be able to interact only with one-way transmitters), depending on which transmitter is memorised first.

4.2 - Groups of programming and adjustment procedures

There are 4 groups of programming and adjustment procedures:

3 ELECTRICAL CONNECTIONS AND FIRST POWER UP

The electrical connections must be made only after installing the motor and compatible accessories required.

The electrical cord of the motor is made up of the following internal cables (**fig. 2**):

Cable	Colour	Connection	 220-230 VAC 50-60 Hz
1	Brown	Power supply phase	
2	Blue	Neutral	
3	Yellow-green	Earth	

3.1 - Connection of motor to electricity mains

Utilise cords 1, 2, 3 (**fig. 2**) to connect the motor to the main and pay attention to the **warnings**:

- improper connection can cause breakdowns and hazardous situations;
- scrupulously respect the connections indicated in this manual;
- in the power supply network of the motor you must install a disconnection device having an opening distance of the contacts that allows complete disconnection in the overvoltage category III conditions, in conformity with the installation rules (disconnection device not supplied with the product).

3.2 - Connection of accessories to motor

- **Accessories can be connected by a radio** (portable transmitters and climatic sensor models with radio data transmission): memorise these accessories in the motor during the programming phases; refer to the procedures given in this manual and those given in the manuals supplied with the devices.

Group A – for motors configured for TWO-WAY communications	 These procedures apply only when the motor is configured for TWO-WAY communications.
Group B – for motors configured for ONE-WAY communications.	 These procedures apply only when the motor is configured for ONE-WAY communications.
Group C – for motors configured for ONE-WAY communication and using a transmitter lacking the PRG and ESC buttons.	 These procedures only apply when the motor is configured for ONE-WAY communication and a transmitter is used that has the ▲ (UP), ■ (STOP) and ▼ (DOWN) buttons, but lacks the PRG and ESC buttons.
Group D – QUICK programming procedures	For information on these procedures, refer to the quick guide supplied with the product and available in digital format on the website www.niceforyou.com .

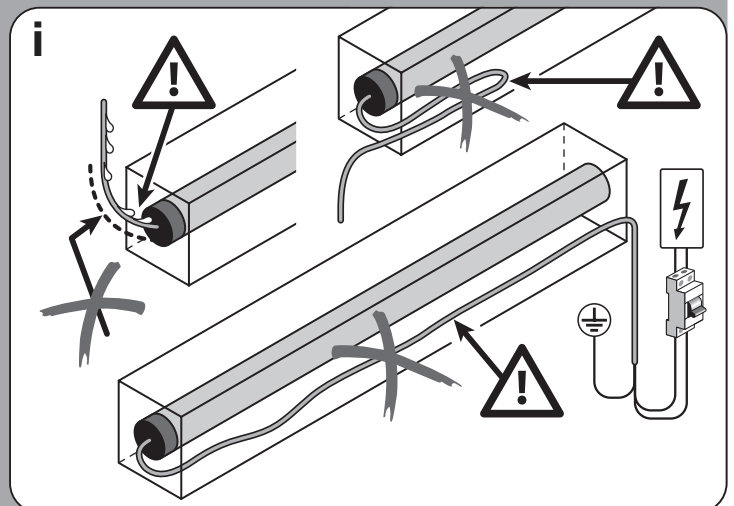
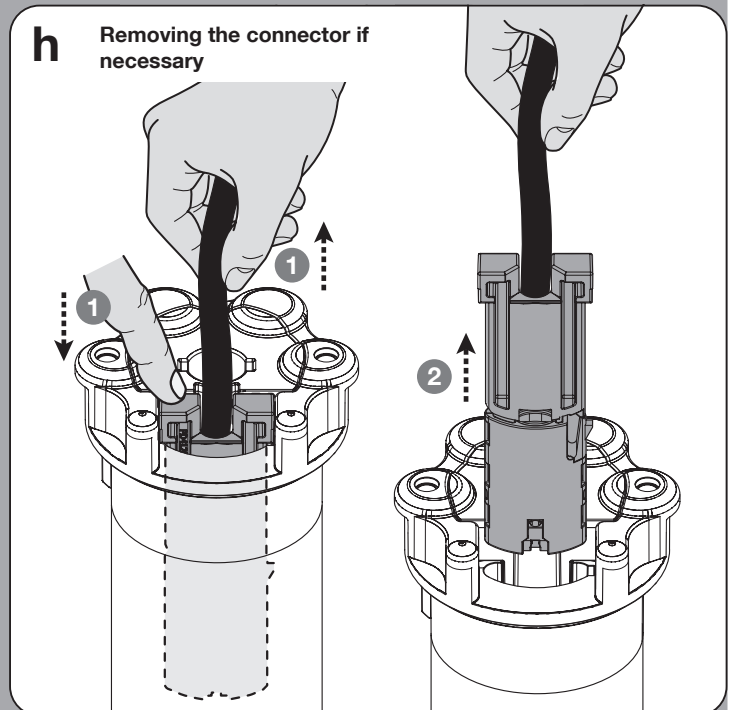
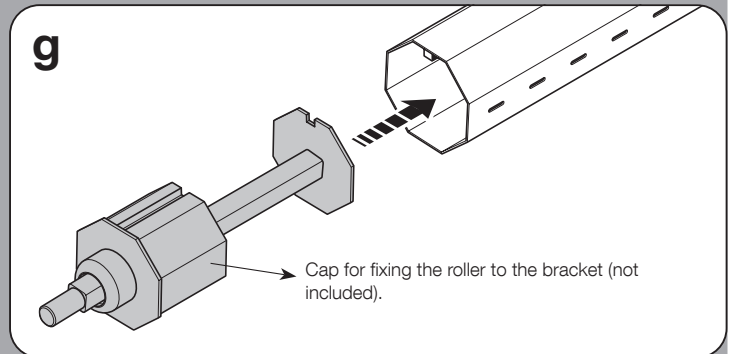
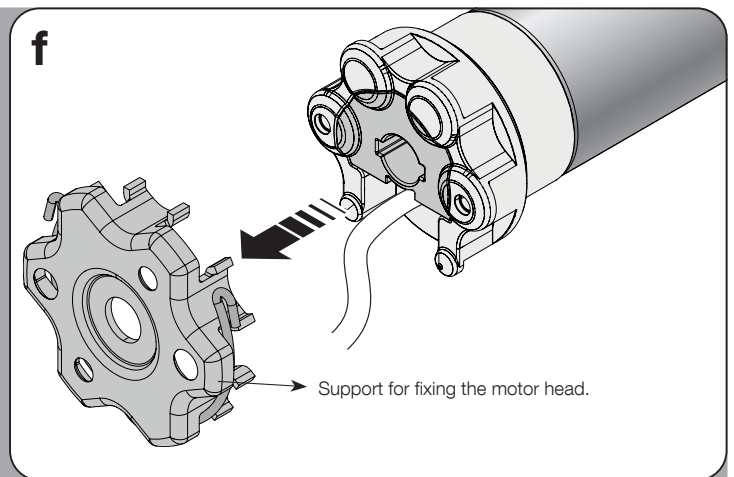
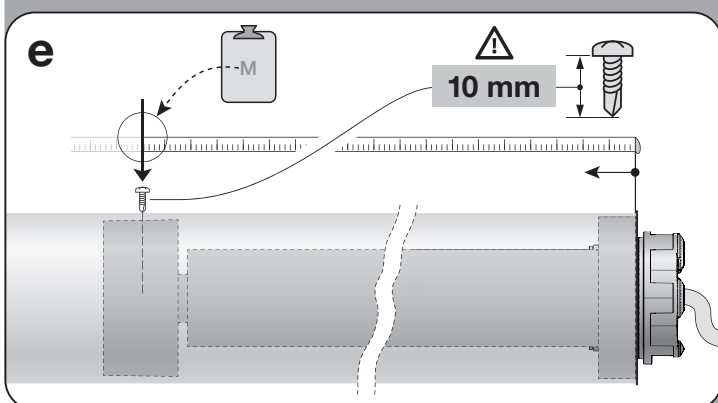
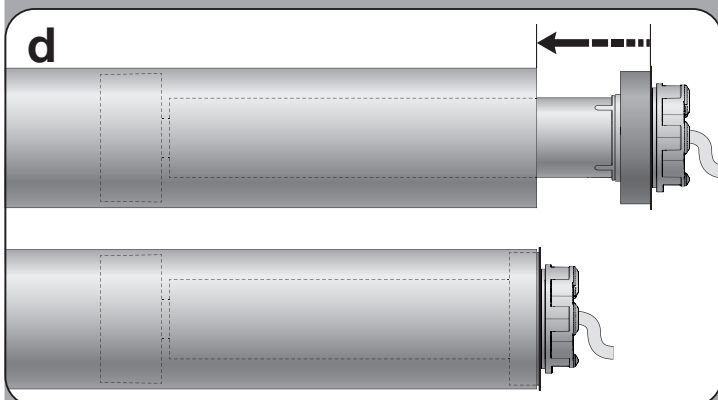
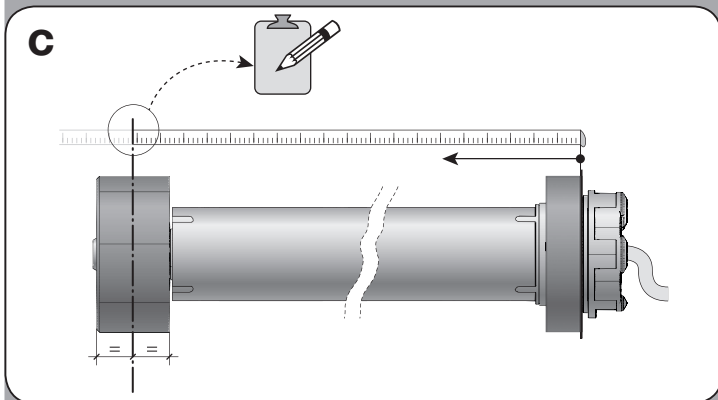
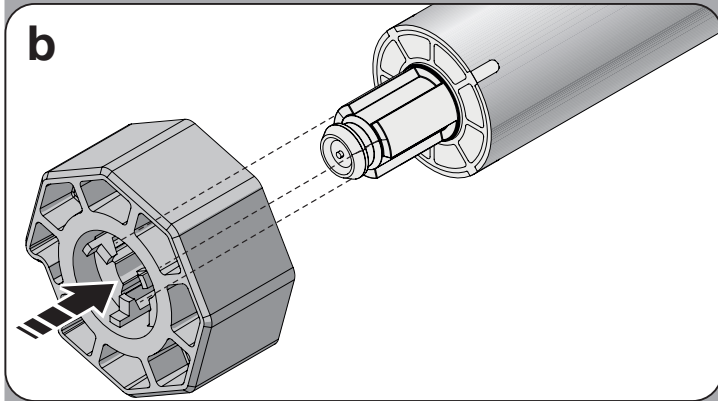
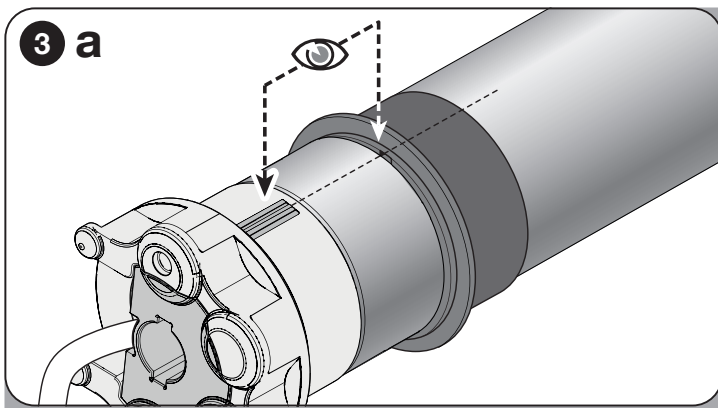

4.3 - Transmitter to be used for programming procedures

- Procedures that can only be completed with a Nice “DOMIP” or “DOMIW” transmitter having the PRG and ESC keys, or with transmitters equipped with a STOP key.
- All the programming procedures must be completed by selecting a single channel on the transmitter.
- The programming procedure must be performed exclusively with a transmitter memorised in “Mode I” (see procedure B.1 - A.1 - D.1).
- If the transmitter used for programming controls multiple automation units, you must select the “unit” corresponding to the automation you are programming before sending a command during a procedure.

4.3.1 - Report messages sent by the motor

The motor repeats the report message on the status of the installation by performing some brief movements when a movement is commanded. To understand the significance of these movements read **Table A**.

No. of MOVEMENTS	Meaning
0 movements (START & STOP)	= 2 limit switches programmed
1 movement (START & STOP)	= 1 limit switch programmed
2 movements (START & STOP)	= no limit switch programmed

4.4 - Positions in which the awning stops automatically

The electronic system that controls the awning’s movement at all times can automatically stop the movement when the awning reaches a certain position programmed by the installer. The programmable positions are (fig. 4):

- position “0” = UPPER (fully wound awning);
- position “1” = LOWER (fully unwound awning);
- position “H” = INTERMEDIATE (partially open awning).

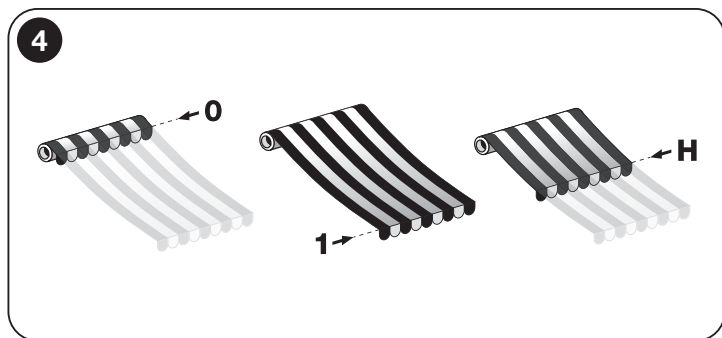

When the limit switches are not programmed yet, the awning can be moved only in the “hold-to-run” mode, i.e. keeping the control key pressed for the desired duration of the manoeuvre; the movement stops as soon as the user releases the key. However, after programming the limit switches, briefly pressing the appropriate key will start the awning and it will stop moving automatically as soon as the awning reaches the required position.

To adjust the distances “0” and “1” various procedures are possible; to choose the appropriate one, take into account the supporting structure of your awning (see the summary in the table).

WARNING! – If you want to again adjust again the height of the limit switches adjusted previously, consider the following:

- If you would like to adjust them with an alternative procedure different from the one used previously, you must **FIRST** delete the heights by following procedure B.12, A.11 or C.4.
- If you wish to adjust the same procedure used previously, you need not delete them.

The programming of the limit switches simultaneously combines the two directions of rotation of the motor to the respective shutter raising key (▲) and shutter lowering key (▼) of the control device (initially, when the limit switches are not programmed yet, the combination is random and it can happen that when pressing the ▲ key, the awning moves down instead of up, or vice versa).

4.5 - General warnings

- The limit switch must be adjusted after installing the motor in the awning and connecting it to the power supply.
- Comply strictly with the time limits indicated in the procedures: after releasing a key, you have 60 seconds to press the next key indicated in the procedure; otherwise, when the time is up, the motor will perform 6 movements to communicate cancellation of the procedure in progress.
- During programming the motor performs a certain number of **brief movements** as a “response” to the command sent by the installer. Count these movements regardless of their direction. The movements are indicated in the procedures with a number followed by the symbol \updownarrow .

4.6 - Important warnings for memorising the radio transmitters

- To select transmitter compatible with the motor’s receiver, refer to the “Nice Screen” catalogue, which is also available on www.niceforyou.com.
- When the motor’s memory does not contain any transmitter, to memorise the **FIRST transmitter**, perform the “Communication mode configuration procedure (ONE-WAY or TWO-WAY)” and subsequently use only one of the following procedures: **B.1** (motor configured as ONE-WAY); **A.1** (motor configured as TWO-WAY); **C.1** (motor configured as ONE-WAY and OLD generation transmitter lacking the PRG and ESC keys). If instead one or more transmitters have already been memorised, to memorise **SUPPLEMENTARY transmitters** use one of following procedures only: **B.6** (motor configured as ONE-WAY); **A.67** (motor configured as TWO-WAY); **C.2** (motor configured as ONE-WAY and OLD generation transmitter lacking the PRG and ESC keys).

4.6.1 - Two procedures to memorise the keys of a transmitter

There are two categories of transmitter memorisation procedures:

A - Procedures which memorise the buttons in “Mode I” (“Standard mode”)

They are procedures B.1 - B.6.1 (motor configured as ONE-WAY); A.1 - A.6 (motor configured as TWO-WAY); C.1 - C.2.1 (motor configured as ONE-WAY and OLD generation transmitter lacking the PRG and ESC keys). These allow you to memorise all buttons at the same time, so that each button corresponds to a basic motor command in a standard fashion.

B - Procedures which memorise the buttons in “Mode II” (“Custom mode”, only applicable when the motor is configured for ONE-WAY communications)

These are procedures B.6.2, A.67 and C.2.2. These allow you to memorise individual buttons and map them to any of the commands given in the motor’s “list of commands” (this list is given in each procedure). The button and the command are selected by the installer, as required by the installation.

4.6.2 - Number of transmitters that can be memorised (only applicable when the motor is configured for ONE-WAY communications)

You can memorise **30 transmitters**, if these are all memorised in “Mode I”, or you can memorise **30 single commands (keys)** if they are all memorised in “Mode II”. The two modes can coexist up to a maximum limit of 30 memorised units.

4.6.3 - Number of transmitters that can be memorised (only applicable when the motor is configured for TWO-WAY communications)

You can memorise **30 transmitters**.

GENERAL WARNINGS RELATING TO THE PROCEDURES

- Before starting any programming, move the awning to an intermediate position, away from the Up and Down limit switches.
- When the motor is powered up, if it makes **2 movements** this means that: at least one transmitter has been memorised and no limit switch has been programmed; if, on the other hand, it makes **1 movement** this means that: no transmitter has been memorised.
- When running a procedure, you can abort the procedure at any time by pressing **ESC** (on the back of the transmitter).
- To change the motor's configuration (from ONE-WAY to TWO-WAY and inversely), it is necessary to perform the "TOTAL deletion of the memory" (B.12 motor configured for ONE-WAY communication, A.11 motor configured for TWO-WAY communication or C.4 motor configured for ONE-WAY communication and **OLD** generation transmitter, lacking the **PRG** and **ESC** buttons) and then switch the motor off and on again.

WARNING: if the motor is new (and does not have any remote control memorised), at the start-up run one of the memorisation procedures for the first transmitter described at points B.1 motor configured for ONE-WAY communication, A.1 motor configured for TWO-WAY communication, or C.1 motor configured for ONE-WAY communication and OLD generation transmitter lacking the PRG and ESC buttons.

In this way, the motor will be configured in the **TWO-WAY** mode (and thus will be able to accept all two-way transmitters) or **ONE-WAY** mode (and thus will be able to interact only with one-way transmitters), depending on which transmitter is memorised first.

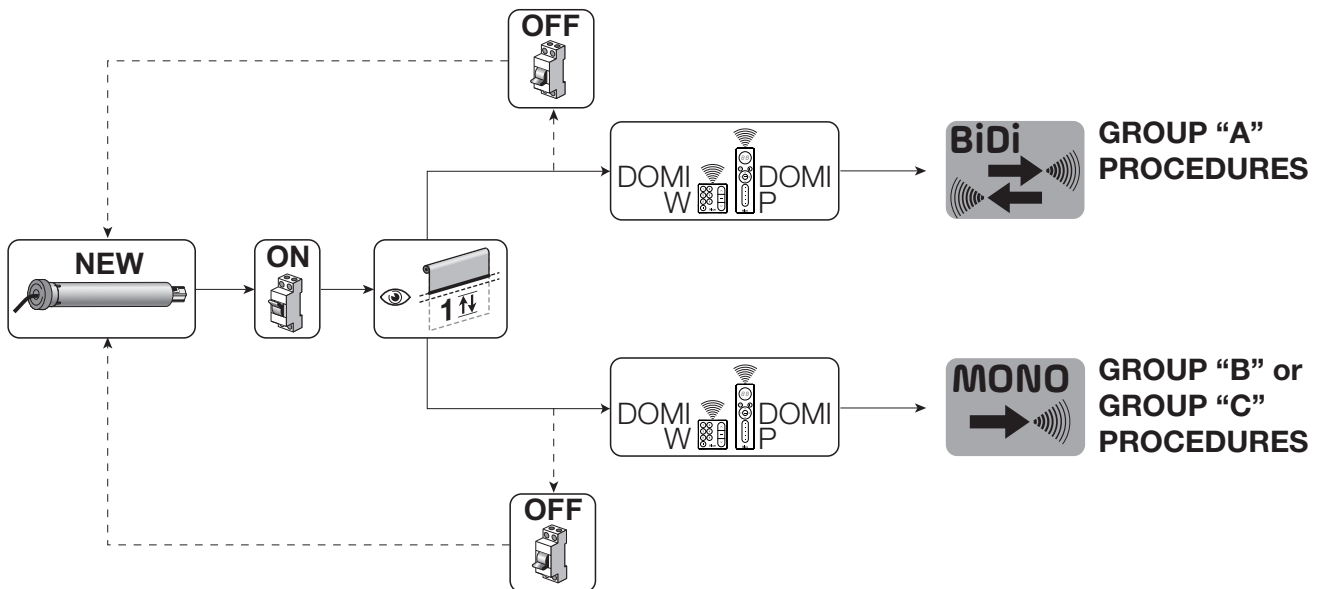

— GROUP “A” PROCEDURES —

for motors configured for TWO-WAY communications

Procedures which can only be completed with a Nice transmitter with the ▲, ■, ▼, PRG, ESC keys (eg. “DOMIP”, “DOMIW”)

GENERAL WARNINGS RELATING TO THE PROCEDURES

- Before starting any programming, move the awning to an intermediate position, away from the Up and Down limit switches.
- All the programming procedures must be completed by selecting a single channel on the transmitter.
- If the programming transmitter controls **multiple groups of screen motors**, before sending a command requested by the procedure, select the group to which the motor being programmed belongs.
- **[*]** When the motor is powered up, if it makes **2 movements** this means that: at least one transmitter has been memorised and no limit switch has been programmed; if, on the other hand, it makes **1 movement** this means that: no transmitter has been memorised.
- When running a procedure, you can abort the procedure at any time by pressing **ESC** (on the back of the transmitter).
- When the Up and Down limit switches are not programmed, the awning can only be commanded in hold-to-run mode - i.e. you must hold the button down until the awning reaches the desired position. The movement stops when you release the button in any position.
- When the Up and Down limit switches have been programmed, the awning can be controlled by simply pressing and releasing the buttons. Doing so starts the movement, which is stopped automatically by the system when the awning reaches the programmed position.
- All procedures require you to use a transmitter memorised in “Mode I” (e.g., memorised with procedure A.1 or with procedure A.6).
- The “deletion carried out with a non-memorised transmitter” procedure does not appear in this section as, for motors configured in TWO-WAY communication mode, it is always possible to access it by completing the “Memorising the FIRST TRANSMITTER A.1” procedure.
- To change the motor’s configuration (from ONE-WAY to TWO-WAY and inversely), it is necessary to perform the “TOTAL deletion of the memory” procedure (B.12 motor configured for ONE-WAY communication, A.11 motor configured for TWO-WAY communication or C.4 motor configured for ONE-WAY communication and OLD generation transmitter, lacking the PRG and ESC buttons) and then switch the motor off and on again.

A A.1 - Memorising the FIRST TRANSMITTER (in “Mode I”)





NOTES AND WARNINGS

- To memorise further transmitters, use the procedure described under section B.6 (motor configured for ONE-WAY communication), A.6 (motor configured for TWO-WAY communication) or C.2 (motor configured for ONE-WAY communication and OLD generation transmitter lacking the PRG and ESC keys).
- If all transmitters memorised in the motor are deleted, the first transmitter you memorise thereafter must be memorised with this procedure.
- If the installation has multiple motors, the procedure must be repeated for each motor separately.
- On completing this procedure, button ▲ will Raise the awning, button ▼ Lower it, and button ■ Stop the movement.
- If within the transmitter’s range there are multiple powered up motors, to memorise the first transmitter in any one of them, **it is not necessary to disconnect power to all other motors**; simply proceed as follows.

1	2	→ 3
Switch on mains power,	Hold down the button and release it after 5 seconds ;	over the next 2 minutes , all motors within the transmitter’s range in which no transmitters have yet been memorised will move their awnings up and down, for random periods of time.
count 1 movement. [*]		

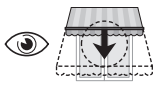
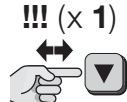
3	→ 4
Select the <u>awning</u> you wish to program and, at the start of an UP movement , stop it IMMEDIATELY , by pressing and releasing the button (1 time):	... the awning will resume its up and down movements, each of random duration.
the movement will stop briefly (= command received) and ...	

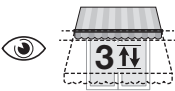
4	end		
			
Observe the same awning and, at the start of a DOWN movement , stop the movement IMMEDIATELY , by pressing and releasing the button (1 time) ;	the movement will stop;	count 3 movements.	

A A.2 - Temporarily deactivating (and reactivating) motors you do not wish to program



NOTES AND WARNINGS

- This procedure temporarily deactivates (for 5 minutes) only motors whose up and down limit switches have already been programmed and must be carried out on each individual motor.

A.2.1 - To temporarily deactivate motors you do not wish to program

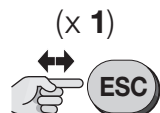
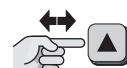
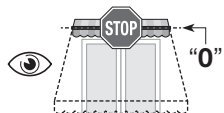

1	2			end
			The system locks out only those motors whose limit switches have already been programmed. It has no effect on motors which have not yet been programmed. The deactivation is temporary and lasts for 5 minutes.	
Press and release the button (1 time) ;	press and release the button;	you will see a brief down movement and a movement which stops the awning at the Up limit "0".	For a period of 5 minutes, the locked out motors will not respond to commands.	

A.2.2 - To reactivate temporarily locked out motors

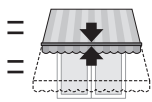
You can reactivate the motors in three ways:

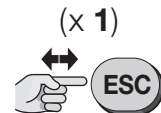
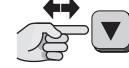
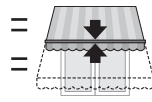
option - A	1	end	
	<p>After 5 minutes the locked out motors are <u>automatically reactivated</u> by the system.</p> <p>Wait for 5 minutes ...</p>	 <p>... the system will then move the awning to the mid position.</p>	

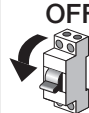
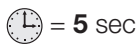
option - B	1	end		
	<p>During the 5 minute period the locked out motors can be <u>reactivated at any time by the user</u>.</p> <p>During the 5 minutes, at any time...</p>	 <p>Press and release the button (1 time);</p>	 <p>press and release the button;</p>	 <p>... the system will then move the awning to the mid position.</p>

option - C	1	end	
	<p>During the 5 minute period the locked out motors can be <u>reactivated at any time by the user</u>.</p> <p>During the 5 minutes, at any time.</p>	  	

A A.3 - MANUAL programming of the UP ("0") and DOWN ("1") limit switches

NOTES AND WARNINGS

- This procedure is obligatory only for awnings without a mechanical stop at the Up position.
- This procedure can be used if the limit switches have been programmed using the semiautomatic procedure (A.4).
- After the limit positions have been programmed, the awning can be controlled by simply pressing the appropriate buttons on the control unit. The awning will move between the positions set with procedures A.3.1 and A.3.2.
- If the limit switches have not been programmed yet, the awning's direction of movement might not match the pressed button.

A.3.1 - To program the UP limit switch ("0")

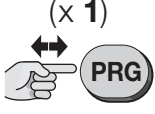
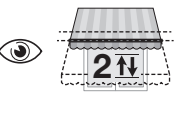
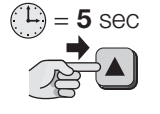
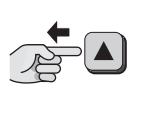
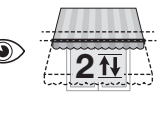
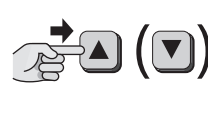
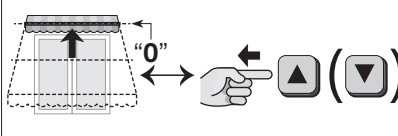
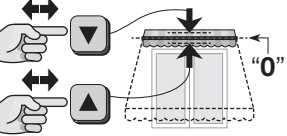
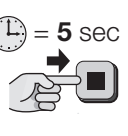
1		2		3 continues →	
					Command an UP movement → 
Press and release the button (1 time);	count 2 movements.	Hold down the button and	release it after 5 seconds;	count 2 movements.	Hold down the button ▲ (or ▼) and wait ...
→ 3		4		5 end	
		Finely adjusting the position of limit switch "0" → 			
... release the button as soon as the awning reaches position "0" (UP limit switch).		Press the buttons until you reach the desired position.		Hold down the button and	
				release it after 5 seconds;	
				count 3 movements.	

A.3.2 - To program the DOWN limit switch ("1")

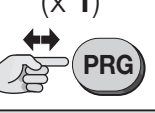
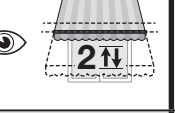
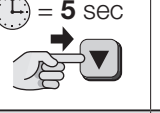
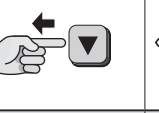
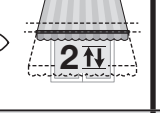
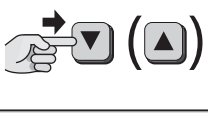
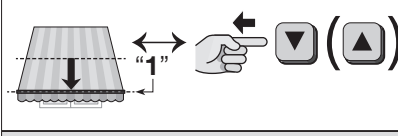
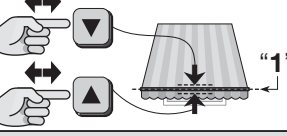
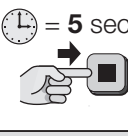
1		2		3 continues →	
					Command an DOWN movement → 
Press and release the button (1 time);	count 2 movements.	Hold down the button and	release it after 5 seconds;	count 2 movements.	Hold down the button ▼ (or ▲) and wait ...
→ 3		4		5 end	
		Finely adjusting the position of limit switch "1" → 			
... release the button as soon as the awning reaches position "1" (DOWN limit switch).		Press the buttons until you reach the desired position.		Hold down the button and	
				release it after 5 seconds;	
				count 3 movements.	

A A.4 - AUTOMATIC programming of the UPPER limit switch ("0") and MANUAL programming of the LOWER limit switch ("1")

NOTES AND WARNINGS

- Use this procedure solely for awnings with mechanical Up "0" limit switch stop.
- Programme the UP limit switch (0) FIRST.
- If, previously, the limit switches were programmed with the "Manual (A.3)" programming, to complete this procedure before proceeding with the "Total or partial deletion of the memory [B.12.1 (motor configured for ONE-WAY communication), A.11.1 (motor configured for TWO-WAY communication) or C.4.1 (motor configured for ONE-WAY communication and OLD generation transmitter lacking the PRG and ESC keys) option 'A' or 'D']".
- If the limit switches have not been programmed yet, the awning's direction of movement might not match the pressed button.
- After the limit positions have been programmed, the awning can be controlled by simply pressing the appropriate buttons on the control unit. The Up movement will be limited when the awning impacts against the mechanical lock (box) in the Upper limit switch "0". With each impact, the height of this limit switch will be automatically updated by the "Automatic limit switch update" function (paragraph 5.4). Conversely, the Down movement will be limited by the Lower limit switch "1" (limit switch set by the installer at a desired point).

1 Command an UP movement → (▼)			2 continues → Command an DOWN movement → (▲)		
Hold down the button ▲ (or ▼) and wait wait for the awning to be stopped when it collides with the box (= UP limit switch = position "0").	release the button.		
→ 2		3 (x 1) 		→ 5	
... release the button as soon as the awning reaches position "1" (DOWN limit switch).		Press and release the button (1 time);	count 2 movements.	Hold down the button and	release it after 5 seconds ;
5 Finely adjusting the position of limit switch "1" →		6 		end	
Press the buttons until you reach the desired position.		Hold down the button and	release it after 5 seconds ;	count 3 movements.	

A A.5 - Programming an INTERMEDIATE POSITION (position "H")

NOTES AND WARNINGS

- This procedure memorises an intermediate position (position "H") between the Up ("0") and Down ("1") limit switch positions. When the automation is being used, after giving the **intermediate position** command, the system will automatically stop the awning at the programmed "H" position.
- Up to 30 "H" positions can be memorised if the motor is configured to operate in ONE-WAY mode, or up to 6 "H" positions if the motor is configured to operate in TWO-WAY mode, in any desired position, provided that they are within the space delimited by the two limit switches. These positions can only be programmed after the limit switch positions. Repeat this procedure for each position you wish to memorise.
- The first "H" position must be programmed using the buttons ▲+▼, **on the transmitter used to run the procedure itself**. However, each subsequent position "H" must be programmed using a button **on another non-memorised transmitter**.
- To change an existing "H" position, move the awning to the desired height and run this procedure; in **step 06**, however, press the button associated with the existing "H" position you are changing.

1 		2 (x 1) 		3 		4 				
Move the awning to the desired "H" position.		Press and release the button (1 time);		count 2 movements.		Hold down both buttons...		release them after 5 seconds ;		
4 Precisely adjusting the "H" position →		5 				6 ... 		Select one of the following options and execute it: • option A – to memorise the <u>FIRST</u> "H" position. • option B – to memorise a <u>SUPPLEMENTARY</u> "H" position.		
Press the buttons until you reach the desired position.		Hold down the button and		release it after 5 seconds ;		count 3 movements.				
option – A	6 						end			
	Hold down both buttons...		release them after 5 seconds ;		count 4 movements.					
option – B	6 						end			
	On ANOTHER transmitter, which has NOT been memorised: hold down <u>any button</u> you wish;		release it after 5 seconds ;		count 4 movements.					

A A.6 - Memorising ANOTHER TRANSMITTER (second, third, etc.)

NOTES AND WARNINGS

- The motor configured to operate in TWO-WAY mode can memorise up to 16 transmitters.
- To run procedures A.6 you must have a **new transmitter** to memorise and an **old previously memorised transmitter**. The two transmitters must have the "PRG" and "ESC" buttons (like "DOMIP" and "DOMIW" transmitters).
- Procedures A.6 memorise all the new transmitter's buttons in "Mode I", with the same configuration as the **old** transmitter (for details about "Mode I" see par. 4.6.1).
- In case you do not have the old previously memorised transmitter available, this programming can also be done with procedure A.1

1		2		→ 3	
On the OLD transmitter: Press and release the button (1 time);	count 2 movements;	On the NEW transmitter: hold down the button and	release it after 5 seconds ;		count 2 movements;
3		4		end	
On the OLD transmitter: Press and release the button (1 time);	count 2 movements;	On the NEW transmitter: Press and release the button (1 time);	count 3 movements (= transmitter memorised) .		

A A.7 - "RDC" Function: adjustment of the motor traction force when closing

NOTES AND WARNINGS

- This function prevents the excessive traction of the canvas at the end of the closing manoeuvre. During the final phase of this manoeuvre, the function automatically reduces the motor traction torque, based on the factory setting or the one adjusted by the installer with the following procedure.
- **Warning!** – **Function active and applicable only near the upper limit switch.**
- **Warning!** – **This function is active with the factory setting but is not applicable if the limit switches are programmed with the manual procedure A.3.**

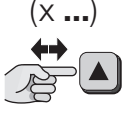
1		2		3		→ 4	
Press and release the button (1 time);	count 2 movements.	Press and release the button (1 time);	count 2 movements.	Hold down both buttons...	release them after 5 seconds ;	count 2 movements.	
4		continues →					
Select the desired option and program it as follows →		 4 OPTIONS: x 1 = standard sensitivity (*) x 2 = minimum sensitivity x 3 = medium sensitivity x 5 = function deactivated					
		Press and release the button the number of times indicated in the option you have chosen;					

→ 4		5		fine	
After about 10 seconds, the motor performs a number of movements equal to the number of pulses entered.		Hold down the button and	release it after 5 seconds ;	count 3 movements.	





(*) = Factory setting.

A A.8 - "FRT" Function: automatic tensioning of the canvas when opening awnings that are not fitted with a mechanism to lock the awning when opening

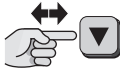
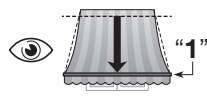

- This function is useful to eliminate the unsightly depression of the canvas that may form when the awning is open. It is activated by programming position "2" near the limit switch "1". The function may only be used in awnings that DO NOT have any mechanism to lock the canvas in the open position. When the function is activated, when using the automation, the awning lowers to the lower limit switch "1" and then automatically raises to position "2" (the one programmed with the following procedure), stretching the canvas. The function also acts when a partial opening/closing manoeuvre is commanded. In these cases the awning stops in correspondence to the height "H" programmed and then rises automatically until the canvas is taut.

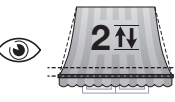
NOTES AND WARNINGS

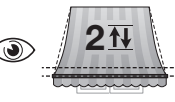
- The "FRT" function may be programmed exclusively after having programmed the limit switch heights "0" and "1".
- Position "2" must be a point between limit switch "1" and limit switch "0".

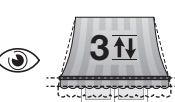
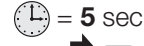
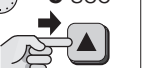
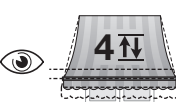
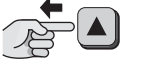
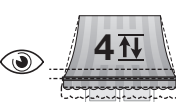
1	→ 4
(x 1) 	
Hold down the button.	
2	→ 4
(x 1) 	
Press and release the button (1 time);	count 2 movements.
3	→ 4
(x 1) 	
Press and release the button (1 time);	count 2 movements.

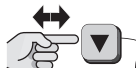
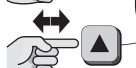
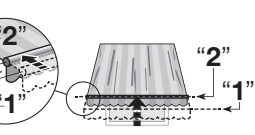
4	→ 6
(x 1) 	
Press and release the button (1 time);	count 3 movements.
5	→ 6
 	
Hold down the button and	count 4 movements.
	
release it after 5 seconds;	

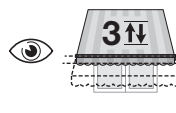
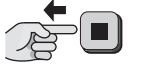
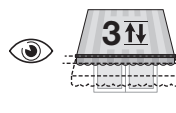
6	end
 	
7	end
 	
Hold down the button and	count 3 movements.
	
release it after 5 seconds;	

A A.9 - Programming the movement (Ascent or Descent) that the motor must perform automatically when it starts to rain (ref. paragraph 6.1.2)



1	2	3	→ 4
Move the awning to a half-way position.	Press and release the button (1 time);	count 2 movements	Press and release the button (1 time); count 2 movements

4	5	6	...
Hold down the button and	release it after 5 seconds ;	count 3 movements.	Hold down the button and count 2 movements release the button.

Programme the movement that the motor must perform automatically when it starts to rain, by selecting one of the following option:

- **option A** – to programme the Raising of the awning.
- **option B** – to programme the Lowering of the awning.

option – A	6	end
Hold down the button and	count 3 movements	release the button.

option – B	6	end
Hold down the button and	count 3 movements	release the button.

A A.10 - Activating/deactivating the “CLIMATIC SPEED CONTROL” function



- With the function active, the motor will vary the manoeuvre speed on the basis of the type of message coming from the climatic sensor: when there is an alarm message, the movements will occur at maximum speed, while with comfort optimisation messages, they will be made at minimum speed.

1	2	3	→ 4
Press and release the button (1 time);	count 2 movements.	Press and release the button (1 time);	Hold down the button and release it after 3 seconds ;

4	5	...
Hold down the button and	release it after 3 seconds ;	count 3 movements.

Select one of the following options and execute it:

- **option A** – to **ACTIVATE** the function
- **option B** – to **deactivate** the function (*)

option – A	5	end
Hold down the button and	release it after 3 seconds ;	count 3 movements.

option – B	5	end
Hold down the button and	release it after 3 seconds ;	count 4 movements.







(*) = Factory setting.

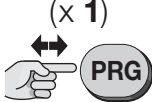

A A.11 - TOTAL or PARTIAL deletion of memory

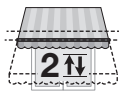
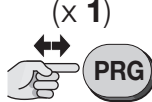

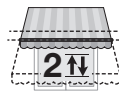
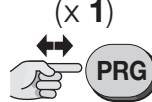
NOTES AND WARNINGS

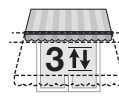

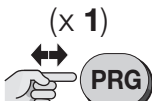

- In order to carry out the following deletion procedures, the transmitter must be memorised in mode I.
- To change the motor's configuration (from TWO-WAY to ONE-WAY), after completing the "FULL deletion of the memory" procedure, it is necessary to switch the motor off and then on again.
- **Once the transmitter has been deleted from the motor's memory, it is necessary to delete from the transmitter's memory the motor that is no longer associated, to prevent "no motor" error messages from appearing on the transmitter (refer to the transmitter manual).**

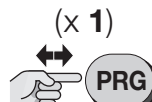

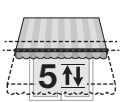

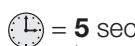

A.11.1 - Procedure run with a memorised transmitter



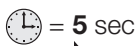

1	(x 1) 	 	2	(x 1) 	 	3	(x 1) 	 	→ 4
	Press and release the button (1 time);	count 2 movements.		Press and release the button (1 time);	count 2 movements.		Press and release the button (1 time);	count 3 movements.	

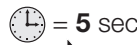
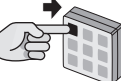
4	(x 1) 	 	5 ...	Select one of the following options and execute it: • option A (*) – delete the motor's ENTIRE memory • option B (*) – delete ALL memorised transmitters • option C (*) – delete ONE memorised transmitter • option D (*) – delete ALL positions ("0", "1", "H", etc.). Caution! – This deletion should only be performed if you wish re-program the distances using a procedure different from the one used previously (e.g. you have used manual distance programming (A.3) and would now like to use the semi-automatic procedure (A.4). (*) Warning! – Once the procedure relative to the chosen option (A, B, C or D) has been completed, perform the dissociation procedure for the two-way remote control (refer to the instructions of the two-way remote control).					
	Press and release the button (1 time);	count 4 movements.							

option – A	5	(x 1) 	 	end
		Press and release the button (1 time);	count 5 movements.	

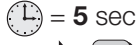
option – B	5	 	 	end
		Hold down the button and	release it after 5 seconds;	count 5 movements.

option – C	5	 	 	6	 	 	end
		Hold down the button and	release it after 5 seconds;	count 3 movements.	On the transmitter to be deleted: hold down any key either the key memorised in mode 2 or the climatic conditions sensor;	count 5 movements.	

option – D	5	 	 	end
		Hold down both buttons...	release them after 5 seconds;	count 5 movements.

A.11.2 - Procedure run with a transmitter which has not yet been memorised

If there is a transmitter that has not been memorized, it must be memorized with procedure A.1. Then carry out procedure A.11.1 to perform the desired type of cancellation.

A A.12 - "MOTOR ROTATION CONTROL" function: regulation of the motor rotations during the first part of the closing manoeuvre

- The application with arm awnings normally requires a lot of power during the initial part of the closing manoeuvre, that is, when the arms are straight. With this function it is possible to set, during the initial part of the upward manoeuvre, a lower speed, equal to 6 rpm, to guarantee more power. It is also possible to personalise the number of rotations with which the motor will move at minimum speed.

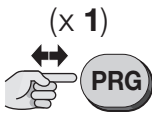
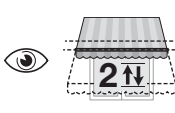
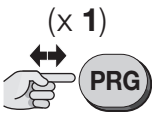
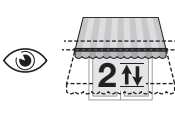
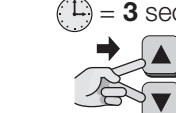
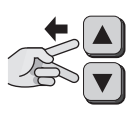
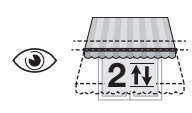
1		2		3		→ 4
						
Press and release the button (1 time);	count 2 movements.	Press and release the button (1 time);	count 2 movements.	Hold down both buttons...	release them after 3 seconds;	count 2 movements.

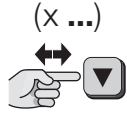
4	continues →
Select the desired option and program it as follows →	 <p>5 OPTIONS:</p> <p>x 1 = function deactivated</p> <p>x 2 = 0,7 turns standard (*)</p> <p>x 3 = 1,5 turns</p> <p>x 4 = 2 turns</p> <p>x 5 = 3 turns</p>
	Press and release the button the number of times indicated in the option you have chosen;

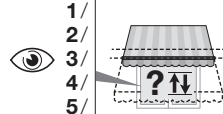
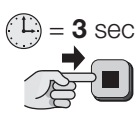
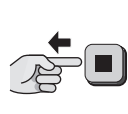
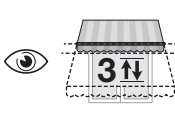
→ 4	5	end		
				
after about 10 seconds, the motor performs a number of movements equal to the number of pulses entered.	Hold down the button and	release it after 3 seconds;		count 3 movements.

(*) = Factory setting.

A A.13 - Adjusting cruising speed

NOTES AND WARNINGS

- For the values of the three options available (minimum, nominal and maximum speed), consult the "Technical specifications" chapter.
- To assess whether the chosen option for the cruising speed is compatible with the awning's characteristics (weight, roller dimensions, torque required), refer to the "Technical specifications" chapter.

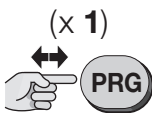
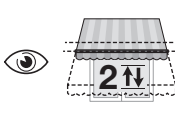
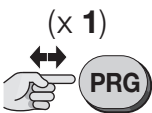
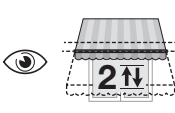
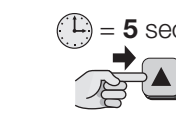
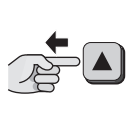
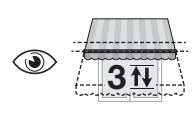
1		2		3		→ 4
						
Press and release the button (1 time);	count 2 movements.	Press and release the button (1 time);	count 2 movements.	Hold down the button and;	release them after 5 seconds;	count 3 movements.

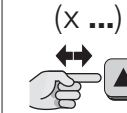
4	continues →
Select the desired option and program it as follows →	 <p>5 OPTIONS:</p> <p>1 press = 6 rpm</p> <p>2 presses = 12 rpm</p> <p>3 presses = 17 rpm (Factory setting)</p> <p>4 presses = 20 rpm</p> <p>5 presses = 24 rpm</p>
	Press and release the button the number of times indicated in the option you have chosen;

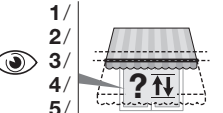
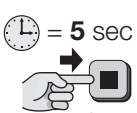
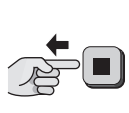
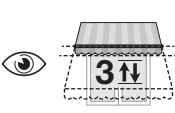
→ 4	5	end		
				
After about 7 seconds, the motor performs a number of movements equal to the number of pulses entered.	Hold down the button and	release it after 5 seconds;		count 3 movements.

— GROUP “B” PROCEDURES —

for motors configured for ONE-WAY communications

procedures which can only be completed with a Nice “DOMIP” or “DOMIW” transmitter with the ▲, ■, ▼, PRG, ESC keys



GENERAL WARNINGS RELATING TO THE PROCEDURES

- Before starting any programming, move the awning to an intermediate position, away from the Up and Down limit switches.
- All the programming procedures must be completed by selecting a single channel on the transmitter.
- If the programming transmitter controls **multiple groups of screen motors**, before sending a command requested by the procedure, select the group to which the motor being programmed belongs.
- **[*]** When the motor is powered up, if it makes **2 movements** this means that: at least one transmitter has been memorised and no limit switch has been programmed; if, on the other hand, it makes **1 movement** this means that: no transmitter has been memorised.
- When running a procedure, you can abort the procedure at any time by pressing **ESC** (on the back of the transmitter).
- When the Up and Down limit switches are not programmed, the awning can only be commanded in hold-to-run mode - i.e. you must hold the button down until the awning reaches the desired position. The movement stops when you release the button in any position.
- When the Up and Down limit switches have been programmed, the awning can be controlled by simply pressing and releasing the buttons. Doing so starts the movement, which is stopped automatically by the system when the awning reaches the programmed position.
- To perform all the procedures, it is necessary to use a transmitter memorised in “Mode I” (for example, the one memorised with procedure B.1 motor configured for ONE-WAY communication, A.1 motor configured for TWO-WAY communication or C.1 motor configured for ONE-WAY communication and OLD generation transmitter lacking the PRG and ESC keys).
- To change the motor’s configuration (from ONE-WAY to TWO-WAY and inversely), it is necessary to perform the “TOTAL deletion of the memory” procedure (B.12 motor configured for ONE-WAY communication, A.11 motor configured for TWO-WAY communication or C.4 motor configured for ONE-WAY communication and OLD generation transmitter, lacking the PRG and ESC buttons) and then switch the motor off and on again.

B B.1 - Memorising the FIRST TRANSMITTER (in “Mode I”) 

NOTES AND WARNINGS

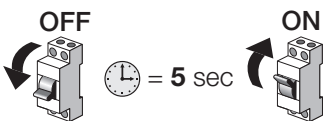
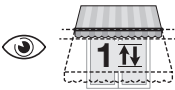
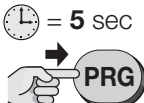
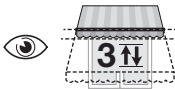









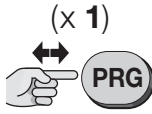

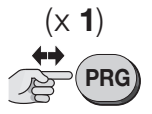

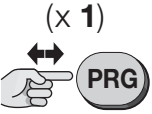

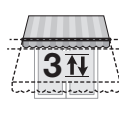

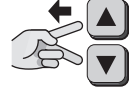
- This procedure must be used only for memorising the FIRST TRANSMITTER. **If the motor does not perform the procedure, it means that one or more transmitters are already memorised**; therefore, to memorise further transmitters, use the procedure described under section B.6 (motor configured for ONE-WAY communication), A.6 (motor configured for TWO-WAY communication) or C.2 (motor configured for ONE-WAY communication and OLD generation transmitter lacking the PRG and ESC keys).
- If all transmitters memorised in the motor are deleted, the first transmitter you memorise thereafter must be memorised with this procedure.
- If the installation has multiple motors, the procedure must be repeated for each motor separately.
- Once the first transmitter has been memorised, the raising and lowering direction of the awning will not yet be associated with the ▲ and ▼ buttons of the transmitter. This combination will occur automatically when adjusting the up (“0”) and down (“1”) limit switches (see procedure B.3); moreover, the awning will only move in “hold-to-run” mode during the time in which the limit switches have not yet been adjusted.
- If within the transmitter’s range there are multiple powered up motors, to memorise the first transmitter in any one of them, **it is necessary to disconnect the power supply to all other motors** and proceed as follows:

1		2			end
					
Switch on mains power,	count 1 movement. [*]	Hold down the button and	release it after 5 seconds ;	release the button.	

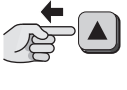
B B.2 - Locking and unlocking the motor's memory MONO

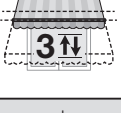
NOTES AND WARNINGS

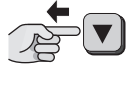
- Locking the motor's memory stops any other (unscheduled or unauthorised) transmitters being memorised in it.

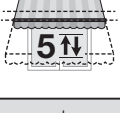









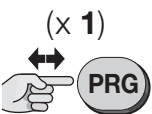

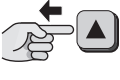

1	(x 1) 	 	2	(x 1) 	 	3	(x 1) 	 	→ 4
	Press and release the button (1 time);	count 2 movements.		Press and release the button (1 time);	count 2 movements.		Press and release the button (1 time);	count 3 movements.	
4	 = 5 sec 		 	5 ...					
	Hold down both buttons...	release them after 5 seconds;	count 4 movements.	Select one of the following options and execute it:					
option - A			option A - LOCK motor's memory.						
5	 = 5 sec 		 	option B - UNLOCK motor's memory.					
	Hold down the button and	release it after 5 seconds;	count 3 movements.						
option - B			option B - UNLOCK motor's memory.						
5	 = 5 sec 		 	end					
	Hold down the button and	release it after 5 seconds;	count 5 movements.						

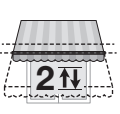
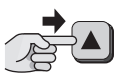
B B.3 - MANUAL programming of the UP ("0") and DOWN ("1") limit switches MONO

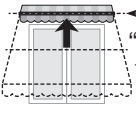
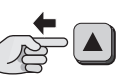
NOTES AND WARNINGS

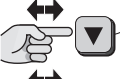
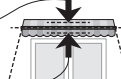
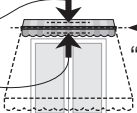
- This procedure is obligatory only for awnings without a mechanical stop at the Up position.
- This procedure can be used if the limit switches have been programmed using the semiautomatic procedure (B.4).
- After the limit positions have been programmed, the awning can be controlled by simply pressing the appropriate buttons on the control unit. The awning will move between the positions set with procedures B.3.1 and B.3.2.
- If the limit switches have not been programmed yet, the awning's direction of movement might not match the pressed button

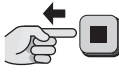
B.3.1 - To program the UP limit switch ("0")

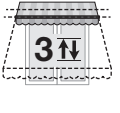
1	(x 1) 	 	2	 = 5 sec 		 	3	Command an UP movement →  ()	continues →	
	Press and release the button (1 time);	count 2 movements.		Hold down the button and	release it after 5 seconds;	count 2 movements.		Hold down the button ▲ (or ▼) and wait ...		
→ 3	  ()		4	Regolare con precisione la quota del finecorsa "0" →   		5	 = 5 sec 		 	end
	... release the button as soon as the awning reaches position "0" (UP limit switch).			Press the buttons until you reach the desired position.			Hold down the button and	release it after 5 seconds;	count 3 movements.	

B.3.2 - To program the DOWN limit switch ("1")

1		2			3 continues →	
(x 1) 					Comandare una manovra di DISCESA → 	
Press and release the button (1 time);	count 2 movements.	Hold down the button and	release it after 5 seconds;	count 2 movements.	Hold down the button ▼ (or ▲) and wait ...	
→ 3		4		5 end		
		Regolare con precisione la quota del finecorsa "1" → 				
... release the button as soon as the awning reaches position "1" (DOWN limit switch).		Press the buttons until you reach the desired position.		Hold down the button and	release it after 5 seconds;	count 3 movements.

B B.4 - AUTOMATIC programming of the UPPER limit switch ("0") and MANUAL programming of the LOWER limit switch ("1")

NOTES AND WARNINGS





- Use this procedure solely for awnings with mechanical Up "0" limit switch stop.
- Programme the UP limit switch (0) FIRST.
- If, previously, the limit switches were programmed with the "Manual (A.3)" programming, to complete this procedure before proceeding with the "Total or partial deletion of the memory [B.12.1 (motor configured for ONE-WAY communication), A.11.1 (motor configured for TWO-WAY communication) or C.4.1 (motor configured for ONE-WAY communication and OLD generation transmitter lacking the PRG and ESC keys) option 'A' or 'D']".
- If the limit switches have not been programmed yet, the awning's direction of movement might not match the pressed button.
- After the limit positions have been programmed, the awning can be controlled by simply pressing the appropriate buttons on the control unit. The Up movement will be limited when the awning impacts against the mechanical lock (box) in the Upper limit switch "0". With each impact, the height of this limit switch will be automatically updated by the "Automatic limit switch update" function (paragraph 5.4). Conversely, the Down movement will be limited by the Lower limit switch "1" (limit switch set by the installer at a desired point).

1			2 continues →			
Command an UP movement → 			Command an DOWN movement → 			
Hold down the button ▲ (or ▼) and wait wait for the awning to be stopped when it collides with the box (= UP limit switch = position "0").	release the button.	Hold down the button ▼ (or ▲) and wait ...			
→ 2		3		4		→ 5
		(x 1) 				
... release the button as soon as the awning reaches position "1" (DOWN limit switch).	Press and release the button (1 time);	count 2 movements.	Hold down the button and	release it after 5 seconds;	count 2 movements.	
5			6 end			
Finely adjusting the position of limit switch "1" → 						
Press the buttons until you reach the desired position.			Hold down the button and	release it after 5 seconds;	count 3 movements.	

B B.5 - Programming an INTERMEDIATE POSITION (position "H") MONO

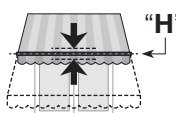
NOTES AND WARNINGS

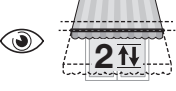
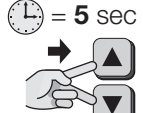
- This procedure memorises an intermediate position (position "H") between the Up ("0") and Down ("1") limit switch positions. When the automation is being used, after giving the **intermediate position** command, the system will automatically stop the awning at the programmed "H" position.
- Up to 30 "H" positions can be memorised if the motor is configured to operate in ONE-WAY mode, or up to 6 "H" positions if the motor is configured to operate in TWO-WAY mode, in any desired position, provided that they are within the space delimited by the two limit switches. These positions can only be programmed after the limit switch positions. Repeat this procedure for each position you wish to memorise.
- The first "H" position must be programmed using the buttons ▲+▼, **on the transmitter used to run the procedure itself**. However, each subsequent position "H" must be programmed using a button **on another non-memorised transmitter**.
- To change an existing "H" position, move the awning to the desired height and run this procedure; in **step 06**, however, press the button associated with the existing "H" position you are changing.

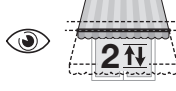
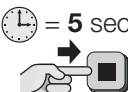
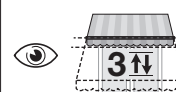
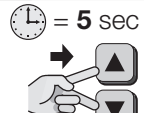
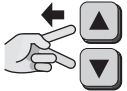
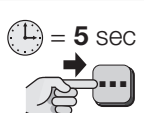
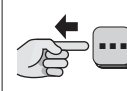
1	2		3		→ 4
	(x 1) 				
Move the awning to the desired "H" position.	Press and release the button (1 time);	count 2 movements.	Hold down both buttons...	release them after 5 seconds ;	count 2 movements.
4	5			6 ...	
Precisely adjusting the "H" position →					
Press the buttons until you reach the desired position.	Hold down the button and			release it after 5 seconds ;	
			count 3 movements.		
Select one of the following options and execute it:					
• option A – to memorise the <u>FIRST</u> "H" position.					
• option B – to memorise a <u>SUPPLEMENTARY</u> "H" position.					
6	end			6	
option - A					
Hold down both buttons...	release them after 5 seconds ;			count 4 movements.	
option - B					
	On ANOTHER transmitter, which has NOT been memorised: hold down <u>any button</u> you wish;			release it after 5 seconds ;	
			count 4 movements.		







B B.6 - Memorising ANOTHER TRANSMITTER (second, third, etc.) MONO

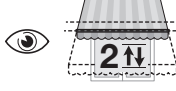

NOTES AND WARNINGS

- The motor configured to operate in ONE-WAY mode can memorise up to 30 transmitters.
- To run procedure B.6.1, you must have a **new transmitter** to memorise and an **old** previously memorised transmitter. The two transmitters must have the "PRG" and "ESC" buttons (like "DOMIP" and "DOMIW" transmitters).
- To run procedure B.6.2 you must have a **new transmitter** to memorise, chosen from the "Nice Screen" catalogue, and an **old** previously memorised transmitter.

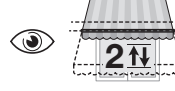
B.6.1 - To memorise the transmitter buttons in "Mode I" ("Standard mode")



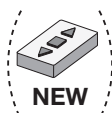
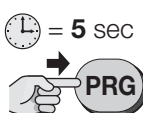
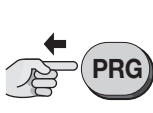
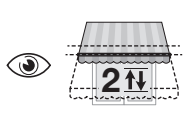

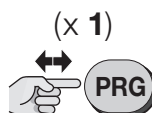
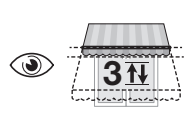
- Procedure B.6.1 memorise all the new transmitter's buttons in "Mode I", with the same configuration as the old transmitter (for details about "Mode I" see par. 4.6.1).



1	→ 2				
					
On the OLD transmitter: hold down the button and	count 2 movements;	wait again...	count 2 more movements;	release the button.	

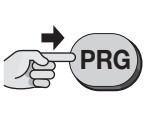
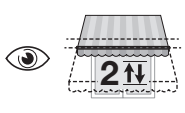

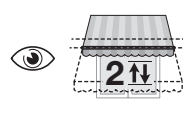
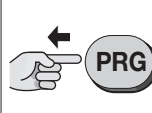

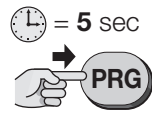
2			3			end
						
On the NEW transmitter: hold down the button and			release it after 5 seconds ;	count 2 movements.		On the OLD transmitter: press and release the button (1 time);
						count 3 movements (= transmitter memorised) . If the system makes 6 movements (= memory locked or full, transmitter not memorised).

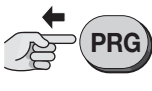
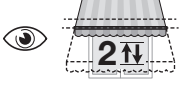
B.6.2 - To memorise the transmitter buttons in “Mode II” (“Custom mode”)

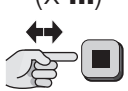
- Procedure B.6.2 memorise a single button on the new transmitter in Mode II; i.e. they associate with the button (chosen by the installer) one of the commands in the motor’s “list of commands” (for details on “Mode II” see section 4.6.1).
- Procedures B.6.2 memorise a single button. Repeat this operation to memorise another button.

1					2		continues →
							
On the OLD transmitter: Hold down the button and wait...		count 2 movements;	wait again...	count 2 more movements;	release the button.	On the NEW transmitter: hold down the button and	

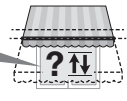
→ 2		3			continues →
		Select the desired option and program it as follows →			
release it after 5 seconds ;	count 2 movements.			4 OPTIONS: 1 press = Open > Stop > Close > Stop > ... 2 presses = Open 3 presses = Close 4 presses = Stop	
		On the OLD transmitter: Press and release the button the number of times indicated in the option you have chosen;			

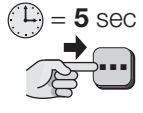
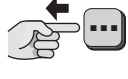
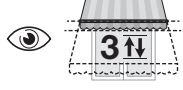
→ 3			4			end
						
After about 7 seconds, the motor performs a number of movements equal to the number of pulses entered.			On the NEW transmitter: select the button you want to memorise; hold it down and		release it after 5 seconds ;	count 3 movements (= transmitter memorised) . If the system makes 6 movements (= memory locked or full, transmitter not memorised).

B B.7 - "RDC" Function: adjustment of the motor traction force when closing



NOTES AND WARNINGS

- This function prevents the excessive traction of the canvas at the end of the closing manoeuvre. During the final phase of this manoeuvre, the function automatically reduces the motor traction torque, based on the factory setting or the one adjusted by the installer with the following procedure.
- Warning! – Function active and applicable only near the upper limit switch.**
- Warning! – This function is active with the factory setting but is not applicable if the limit switches are programmed with the manual procedure B.3.**

1		2		3		→ 4
(x 1) 		(x 1) 				
Press and release the button (1 time);	count 2 movements.	Press and release the button (1 time);	count 2 movements.	Hold down both buttons...	release them after 5 seconds;	count 2 movements.

4	continues →
Select the desired option and program it as follows →	<p>4 OPTIONS: x 1 = standard sensitivity (*) x 2 = minimum sensitivity x 3 = medium sensitivity x 5 = function deactivated</p>
	Press and release the button the number of times indicated in the option you have chosen;

→ 4	5	fine		
After about 10 seconds, the motor performs a number of movements equal to the number of pulses entered.	Hold down the button and	release it after 5 seconds;	count 3 movements.	

(*) = Factory setting.

B B.8 - "FRT" Function: automatic tensioning of the canvas when opening awnings that are not fitted with a mechanism to lock the awning when opening



- This function is useful to eliminate the unsightly depression of the canvas that may form when the awning is open. It is activated by programming position "2" near the limit switch "1". The function may only be used in awnings that DO NOT have any mechanism to lock the canvas in the open position. When the function is activated, when using the automation, the awning lowers to the lower limit switch "1" and then automatically raises to position "2" (the one programmed with the following procedure), stretching the canvas. The function also acts when a partial opening/closing manoeuvre is commanded. In these cases the awning stops in correspondence to the height "H" programmed and then rises automatically until the canvas is taut.

NOTES AND WARNINGS

- The "FRT" function may be programmed exclusively after having programmed the limit switch heights "0" and "1".
- Position "2" must be a point between limit switch "1" and limit switch "0".

1		2		3		→ 4
(x 1) 		(x 1) 		(x 1) 		
Hold down the button.		Press and release the button (1 time);	count 2 movements.	Hold down the button and Press and release the button (1 time);	count 2 movements.	

4	5	→ 6		
(x 1) 				
Press and release the button (1 time);	count 3 movements.	Hold down the button and	release it after 5 seconds;	count 4 movements.

6	7	end	
	Hold down the button and	release it after 5 seconds ;	count 3 movements.

B B.9 - Memorisation of a climate sensor connected via radio **MONO**

NOTES AND WARNINGS

- To run this procedure, refer to the manual provided with the climate sensor.

B B.10 - Programming the movement (Ascent or Descent) that the motor must perform automatically when it starts to rain (ref. paragraph 6.1.2) **MONO**

1	2	3	→ 4
Move the awning to a half-way position.	Press and release the button (1 time);	count 2 movements	count 2 movements

4	5	6	...
Hold down the button and	release it after 5 seconds ;	count 3 movements.	count 2 movements

Programme the movement that the motor must perform automatically when it starts to rain, by selecting one of the following option:









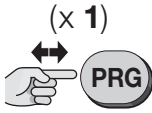

- option A** – to programme the Raising of the awning.
- option B** – to programme the Lowering of the awning.

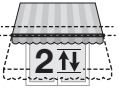
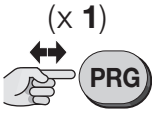

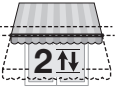



option – A	6	end	
	Hold down the button and	count 3 movements	release the button.





option – B	6	end	
	Hold down the button and	count 3 movements	release the button.



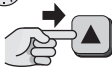

B B.11 - Activating/deactivating the "CLIMATIC SPEED CONTROL" function MONO

- With the function active, the motor will vary the manoeuvre speed on the basis of the type of message coming from the climatic sensor: when there is an alarm message, the movements will occur at maximum speed, while with comfort optimisation messages, they will be made at minimum speed.

1	(x 1) 	 	2	(x 1) 	 	3	 = 3 sec 	 	 	→ 4
	Press and release the button (1 time);	count 2 movements.		Press and release the button (1 time);	count 2 movements.	Hold down the button and	release it after 3 seconds;	count 3 movements.		

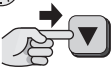
4	 = 3 sec 	 	 	5 ...
Hold down the button and	release it after 3 seconds;	count 3 movements.		Select one of the following options and execute it:
				<ul style="list-style-type: none"> option A – to ACTIVATE the function option B – to deactivate the function (*)

option – A	5	 = 3 sec 	 	 	end
	Hold down the button and	release it after 3 seconds;	count 3 movements.		

option – B	5	 = 3 sec 	 	 	end
	Hold down the button and	release it after 3 seconds;	count 4 movements.		







(*) = Factory setting.

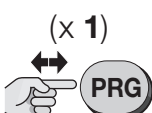

B B.12 - TOTAL or PARTIAL deletion of memory MONO

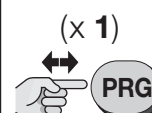
NOTES AND WARNINGS

- In order to carry out the following deletion procedures, the transmitter must be memorised in mode I.
- To change the motor's configuration (from TWO-WAY to ONE-WAY), after completing the "FULL deletion of the memory" procedure, it is necessary to switch the motor off and then on again.

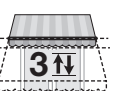
B.12.1 - Procedure run with a memorised transmitter

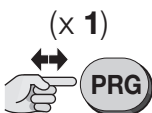
1	(x 1) 	 	2	(x 1) 	 	3	(x 1) 	 	→ 4
	Press and release the button (1 time);	count 2 movements.		Press and release the button (1 time);	count 2 movements.		Press and release the button (1 time);	count 3 movements.	

4	(x 1) 	 	5 ...
Press and release the button (1 time);	count 4 movements.		Select one of the following options and execute it:
			<ul style="list-style-type: none"> option A – delete the motor's ENTIRE memory option B – delete ALL memorised transmitters option C – delete ONE memorised transmitter option D – delete ALL positions ("0", "1", "H", etc.). Caution! – This deletion should only be performed if you wish re-program the distances using a procedure different from the one used previously (e.g. you have used manual distance programming (B.3) and would now like to use the semi-automatic procedure (B.4).

option - A	5	end
	Press and release the button (1 time);	count 5 movements.

option - B	5	end
	Hold down the button and	release it after 5 seconds; count 5 movements.

option - C	5	6	end
	Hold down the button and	release it after 5 seconds; count 3 movements.	
		On the transmitter to be deleted: hold down any key either the key memorised in mode 2 or the climatic conditions sensor;	
			count 5 movements.

option - D	5	end
	Hold down both buttons...	release them after 5 seconds; count 5 movements.

B.12.2 - Procedure run with a transmitter which has not yet been memorised

NOTES AND WARNINGS

- In order to carry out the following procedures, a transmitter with a PRG button should be used.

1	2	3	→ 4
Disconnect the electrical power supply to the motor.		Reconnect the electrical power supply to the motor once again.	

4	5	6	→ 7
Hold down the button and;			release them after 5 seconds;
<----- Within 10 seconds ----->			

7	8	9	10 ...
			Run procedure B.12.1. in full.
Disconnect the electrical power supply to the motor.		Reconnect the electrical power supply to the motor once again.	

B B.13 - "MOTOR ROTATION CONTROL" function: regulation of the motor rotations during the first part of the closing manoeuvre



- The application with arm awnings normally requires a lot of power during the initial part of the closing manoeuvre, that is, when the arms are straight. With this function it is possible to set, during the initial part of the upward manoeuvre, a lower speed, equal to 6 rpm, to guarantee more power. It is also possible to personalise the number of rotations with which the motor will move at minimum speed.

1		2		3		→ 4
Press and release the button (1 time);	count 2 movements.	Press and release the button (1 time);	count 2 movements.	Hold down both buttons...	release them after 3 seconds ;	count 4 movements.

4	continues →	
Select the desired option and program it as follows →	(X ...)	5 OPTIONS: x 1 = function deactivated x 2 = 0,7 turns standard (*) x 3 = 1,5 turns x 4 = 2 turns x 5 = 3 turns
Press and release the button the number of times indicated in the option you have chosen;		

→ 4	5	end	
after about 10 seconds, the motor performs a number of movements equal to the number of pulses entered.	Hold down the button and	release it after 3 seconds ;	count 3 movements.

(*) = Factory setting.

B B.14 - Adjusting cruising speed



NOTES AND WARNINGS

- For the values of the three options available (minimum, nominal and maximum speed), consult the "Technical specifications" chapter.
- To assess whether the chosen option for the cruising speed is compatible with the awning's characteristics (weight, roller dimensions, torque required), refer to the "Technical specifications" chapter.

1		2		3		→ 4
Press and release the button (1 time);	count 2 movements.	Press and release the button (1 time);	count 2 movements.	Hold down the button and;	release them after 5 seconds ;	count 3 movements.

4	continues →	
Select the desired option and program it as follows →	(X ...)	5 OPTIONS: 1 press = 6 rpm 2 presses = 12 rpm 3 presses = 17 rpm (Factory setting) 4 presses = 20 rpm 5 presses = 24 rpm
Press and release the button the number of times indicated in the option you have chosen;		

→ 4	5	end	
After about 7 seconds, the motor performs a number of movements equal to the number of pulses entered.	Hold down the button and	release it after 5 seconds ;	count 3 movements.

— GROUP “C” PROCEDURES —

for motors configured for ONE-WAY communication mode

feasible only with a Nice transmitter equipped with buttons ▲, ■, and ▼ alone and lacking the PRG and ESC buttons

GENERAL WARNINGS RELATING TO THE PROCEDURES







- Before starting any programming, move the awning to an intermediate position, away from the Up and Down limit switches.
- All the programming procedures must be completed by selecting a single channel on the transmitter.
- If the programming transmitter controls **multiple groups of screen motors**, before sending a command requested by the procedure, select the group to which the motor being programmed belongs.
- When the motor is powered up, if it makes **2 movements** this means that: at least one transmitter has been memorised and no limit switch has been programmed; if, on the other hand, it makes **1 movement** this means that: no transmitter has been memorised.
- When performing the procedure, you can cancel the programming at any time by holding down ■ and ▼ together for 4 seconds.
- When the Up and Down limit switches are not programmed, the awning can only be commanded in hold-to-run mode - i.e. you must hold the button down until the awning reaches the desired position. The movement stops when you release the button in any position.
- When the Up and Down limit switches have been programmed, the awning can be controlled by simply pressing and releasing the buttons. Doing so starts the movement, which is stopped automatically by the system when the awning reaches the programmed position.
- All procedures require you to use a transmitter memorised in “Mode I” (e.g., memorised with procedure C.1 or with procedure C.2.1).

C C.1 - Memorising the FIRST TRANSMITTER (in “Mode I”)

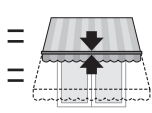

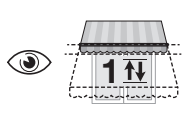
NOTES AND WARNINGS

- This procedure must be used only for memorising the FIRST TRANSMITTER. **If the motor does not perform the procedure, it means that one or more transmitters are already memorised**; therefore, to memorise further transmitters, use the procedure described under section B.6 (motor configured for ONE-WAY communication), A.6 (motor configured for TWO-WAY communication) or C.2 (motor configured for ONE-WAY communication and OLD generation transmitter lacking the PRG and ESC keys).
- If all transmitters memorised in the motor are deleted, the first transmitter you memorise thereafter must be memorised with this procedure.
- If the installation has multiple motors, the procedure must be repeated for each motor separately.
- Once the memorisation has been completed, the Up and Down directions of the awning will not yet be associated with the respective ▲ and ▼ buttons of the transmitter. This will occur automatically when adjusting limit switches “0” and “1” (see procedure C.6); moreover, the awning will move in “hold-to-run” mode until the limit switches have been adjusted.
- If within the transmitter’s range there are multiple powered up motors, to memorise the first transmitter in any one of them, **it is necessary to disconnect the power supply to all other motors** and proceed as follows:

1	2	3	end		
					
Move the awning to a half-way position.	Switch on mains power,	count 1 movement.	Hold down the button and	release it after 5 seconds ;	release the button.

C.2 - Memorising ANOTHER TRANSMITTER (second, third, etc.)







NOTES AND WARNINGS

- The motor configured to operate in ONE-WAY mode can memorise up to 30 transmitters.
- To run procedure C.2.1, you must have a **new transmitter** to memorise and an **old** previously memorised transmitter. The two transmitters must have the "PRG" and "ESC" buttons (like "DOMIP" and "DOMIW" transmitters).
- To run procedure C.2.2 you must have a **new transmitter** to memorise, chosen from the "Nice Screen" catalogue, and an **old** previously memorised transmitter.





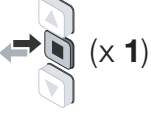
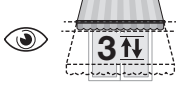



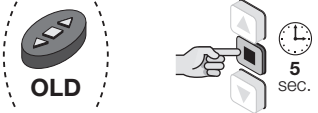

C.2.1 - To memorise the transmitter buttons in "Mode I" ("Standard mode")

- Procedure C.2.1 memorise all the **new transmitter's** buttons in "Mode I", with the same configuration as the **old** transmitter (for details about "Mode I" see par. 4.6.1).

1	2 → 3
  <p>NEW</p>	 <p>OLD</p>
<p>On the OLD transmitter: hold down the button and</p>	<p>release it after 8 seconds.</p> <p>On the OLD transmitter: press and release the button (3 times), provided the button is memorised.</p>
3	end
  <p>NEW</p>	
<p>On the NEW transmitter: press and release the button (1 time);</p>	<p>count 3 movements (= transmitter memorised). If the system makes 6 movements (= memory locked or full, transmitter not memorised).</p>

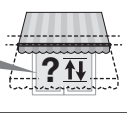
C.2.2 - To memorise the transmitter buttons in "Mode II" ("Custom mode")

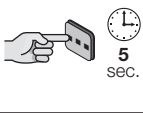
- Procedure C.2.2 memorise a **single button on the new transmitter** in Mode II; i.e. they associate with the button (chosen by the installer) one of the commands in the motor's "list of commands" (for details on "Mode II" see section 4.6.1).
- Procedures C.2.2 memorise a **single button**. Repeat this operation to memorise another button.
- When performing the procedure, you can cancel the programming at any time by holding down **■** and **▼** together for **4 seconds**. Alternatively, do not press any keys and wait 60 seconds for the motor to perform **6 movements**.

1	2 → 3
  <p>NEW</p>	 <p>OLD</p>
<p>On the NEW transmitter: hold down the button you want to memorise;</p>	<p>release it after 8 seconds;</p> <p>On the OLD transmitter: hold down the button and</p> <p>release it after 5 seconds;</p> <p>count 4 movements.</p>
3	continues →
<p>Select the desired option and program it as follows →</p>	  <p>4 OPTIONS: 1 press = Open > Stop > Close > Stop > ... 2 presses = Open 3 presses = Close 4 presses = Stop</p>
<p>On the OLD transmitter: press and release the button the number of times indicated in the option you have chosen;</p>	
→ 3	4 → end
  	   
<p>after about 7 seconds, the motor performs a number of movements equal to the number of pulses entered.</p>	<p>On the NEW transmitter: hold down the same button you pressed in Step 1;</p> <p>release it after 5 seconds;</p> <p>count 3 movements (= transmitter memorised). If the system makes 6 movements (= memory locked or full, transmitter not memorised).</p>

C C.3 - Memorisation of a climate sensor connected via radio



NOTES AND WARNINGS

- To run this procedure, refer to the manual provided with the **climate sensor**.

C C.4 - TOTAL or PARTIAL deletion of memory



NOTES AND WARNINGS

- In order to carry out the following deletion procedures, the transmitter must be memorised in mode I.
- To change the motor's configuration (from TWO-WAY to ONE-WAY), after completing the "FULL deletion of the memory" procedure, it is necessary to switch the motor off and then on again.
- When performing the procedure, you can cancel the programming at any time by pressing and holding the **■** and **▼** buttons simultaneously for 4 seconds. Alternatively, do not press any button and wait 60 seconds for the motor to complete 6 movements.

C.4.1 - Procedure run with a memorised transmitter

1			2			→ 3
Press and release the button (1 time);	count 2 movements;	release the button.	Hold down the button and	count 3 movements;	release the button.	

3			4			→ 5
Hold down the button and	count 3 movements;	release the button.	Hold down the button and	count 3 movements;	release the button.	

5 ...

Select one of the following options and execute it:

- option A** – delete the motor's ENTIRE memory
- option B** – delete ALL memorised transmitters
- option C** – delete ONE memorised transmitter
- option D** – delete ALL positions ("0", "1", "H", etc.). **Caution!** – This deletion should only be performed if you wish reprogram the distances using a procedure different from the one used previously (e.g. you have used manual distance programming (C.6) and would now like to use the semi-automatic procedure (C.7)).

option – A	5		end
	Hold down both buttons;	count 5 movements;	release the buttons.

option – B	5		end
		count 5 movements;	

option – C	5			6		end
	Hold down the button and	count 3 movements;	release the button.	On the transmitter to be deleted: hold down any key either the key memorised in mode 2 or the climatic conditions sensor;	count 5 movements.	

option - D	5				end
		5 sec.			
		Hold down the button and	count 5 movements;	release the button.	

C.4.2 - Procedure performed with an unmemorised transmitter

1	2	3	4	5	
2 sec.				8 sec.	
Disconnect the power supply to the motor		Reconnect the power supply	Hold down the button	Release the button.	
3	4	5	6	7	
			Now run the procedure C.4.1.		
2 sec.					
Disconnect the power supply to the motor		Reconnect the power supply.			

C.5 - Locking and unlocking the motor's memory



NOTES AND WARNINGS

- Locking the motor's memory stops any other (unscheduled or unauthorised) transmitters being memorised in it.

1	2	3	4	5
5 sec.		5 sec.		5 sec.
Hold down the button and	count 2 movements;	release the button.	Hold down the button and	count 3 movements;
				release the button.
3	4	5	6	7
5 sec.		5 sec.		5 sec.
Hold down the button and	count 3 movements;	release the button.	Hold down both buttons;	count 2 movements;
				release the buttons.

Select one of the following options and execute it:

- **option A** - LOCK motor's memory.
- **option B** - UNLOCK motor's memory.

option - A	5				end
		5 sec.			
		Mantenere premuto il tasto;	contare 3 movimenti;	rilasciare il tasto.	

option - B	5				end
		5 sec.			
		Hold down the button and	count 5 movements;	release the button.	

C.6 - MANUAL programming of the UP ("0") and DOWN ("1") limit switches



NOTES AND WARNINGS

- This procedure is obligatory only for awnings without a mechanical stop at the Up position.
- This procedure can be used if the limit switches have been programmed using the semiautomatic procedure (C.7).
- After the limit positions have been programmed, the awning can be controlled by simply pressing the appropriate buttons on the control unit. The awning will move between the positions set with procedures C.6.1 and C.6.2.
- If the limit switches have not been programmed yet, the awning's direction of movement might not match the pressed button.
- When performing the procedure, at any time you can cancel it by keeping the **■** and **▼** keys pressed simultaneously for 4 seconds. Otherwise, do not press any key and wait 60 seconds for the motor to perform 6 movements. • After the adjustments, the **▲** key will command the Raising motion and the key **▼** key will command the Lowering motion. The awning will move within the limits defined by the two limit switch heights.

C.6.1 - To program the UP limit switch ("0")

1			2 → 3		
	Hold down the button and	count 2 movements;	release the button.		Hold down the button and
				count 4 movements;	release the button.
3			4 → 5		
	Hold down the button and	count 2 movements;	release the button.	Command an UP movement →	
				Hold down the button ▲ (or ▼) and wait release the button as soon as the awning reaches position "0" (UP limit switch).
5			6 end		
Regolare con precisione la quota del finecorsa "0" →		Press the buttons until you reach the desired position.		Hold down the button and	count 3 movements;
					release the button.

C.6.2 - To program the DOWN limit switch ("1")

1			2 → 3		
	Hold down the button and	count 2 movements;	release the button.		Hold down the button and
				count 4 movements;	release the button.
3			4 → 5		
	Hold down the button and	count 2 movements;	release the button.	Command a DOWN movement →	
				Hold down the button ▲ (or ▼) and wait release the button as soon as the awning reaches position "1" (DOWN limit switch).
5			6 end		
Finely adjusting the position of limit switch "1" →		Press the buttons until you reach the desired position.		Hold down the button and	count 3 movements;
					release the button.

C C.7 - AUTOMATIC programming of the UPPER limit switch ("0") and MANUAL programming of the LOWER limit switch ("1")



NOTES AND WARNINGS

- Use this procedure solely for awnings with mechanical Up "0" limit switch stop.
- Programme the UP limit switch (0) FIRST.
- If, previously, the limit switches were programmed with the "Manual (C.5)" programming, to complete this procedure before proceeding with the "Total or partial deletion of the memory [B.12.1 (motor configured for ONE-WAY communication), A.11.1 (motor configured for TWO-WAY communication) or C.4.1 (motor configured for ONE-WAY communication and OLD generation transmitter lacking the PRG and ESC keys) option 'A' or 'D']".
- If the limit switches have not been programmed yet, the awning's direction of movement might not match the pressed button.
- After the limit positions have been programmed, the awning can be controlled by simply pressing the appropriate buttons on the control unit. The Up movement will be limited when the awning impacts against the mechanical lock (box) in the Upper limit switch "0". With each impact, the height of this limit switch will be automatically updated by the "Automatic limit switch update" function (paragraph 5.4). Conversely, the Down movement will be limited by the Lower limit switch "1" (limit switch set by the installer at a desired point).
- When performing the procedure, at any time you can cancel it by keeping the ■ and ▼ keys pressed simultaneously for 4 seconds. Otherwise, do not press any key and wait 60 seconds for the motor to perform 6 movements. • After the adjustments, the ▲ key will command the Raising motion and the key ▼ key will command the Lowering motion. During the ascent, the awning will be stopped by the impact against the structure's mechanical stops (= Up "0" limit switch), while during the descent the awning will stop at the down limit switch ("1") defined by the installer.

1			2	continues →
Command an UP movement → 			Comandare una manovra di DISCESA → 	
Hold down the button ▲ (or ▼) and wait wait for the awning to be stopped when it collides with the box (= UP limit switch = position "0").	release the button.	Hold down the button ▼ (or ▲) and wait ...	

→ 2	3	→ 4
... release the button as soon as the awning reaches position "1" (DOWN limit switch).	Hold down the button and	count 2 movements; release the button.

4			5			→ 6
Hold down the button and	count 4 movements;	release the button.	Hold down the button and	count 2 movements;	release the button.	

6			7			end
Regolare con precisione la quota del finecorsa "1" → 						
Press the buttons until you reach the desired position.	Hold down the button and	count 3 movements;	release the button.			

C C.8 - Programming an INTERMEDIATE POSITION (position "H")



NOTES AND WARNINGS

- This procedure memorises an intermediate position (position "H") between the Up ("0") and Down ("1") limit switch positions. When the automation is being used, after giving the **intermediate position** command, the system will automatically stop the awning at the programmed "H" position.
- Up to 30 "H" positions can be memorised if the motor is configured to operate in ONE-WAY mode, or up to 6 "H" positions if the motor is configured to operate in TWO-WAY mode, in any desired position, provided that they are within the space delimited by the two limit switches. These positions can only be programmed after the limit switch positions. Repeat this procedure for each position you wish to memorise.
- The first "H" position must be programmed using the buttons ▲+▼, **on the transmitter used to run the procedure itself**. However, each subsequent position "H" must be programmed using a button **on another non-memorised transmitter**.
- To change an existing "H" position, move the awning to the desired height and run this procedure; in **step 06**, however, press the button associated with the existing "H" position you are changing.

1			2			→ 3
Hold down the button and	count 2 movements;	release the button.	Hold down the button and	count 4 movements;	release the button.	

3			4			→ 5
			Precisely adjusting the "H" position →			
Hold down both buttons...	count 2 movements;	release the buttons.	Press the buttons until you reach the desired position.			

5			6			...
Hold down the button and	count 3 movements;	release the button.				

Select one of the following options and execute it:

- **option A** – to memorise the **FIRST** "H" position.
- **option B** – to memorise a **SUPPLEMENTARY** "H" position.

option – A	6			end
	Hold down both buttons...	count 4 movements;	release the buttons.	

option – B	6			end
	On ANOTHER transmitter, which has NOT been memorised: hold down any button you wish;	count 4 movements.		

C C.9 - "RDC" Function: adjustment of the motor traction force when closing



NOTES AND WARNINGS

- This function prevents the excessive traction of the canvas at the end of the closing manoeuvre. During the final phase of this manoeuvre, the function automatically reduces the motor traction torque, based on the factory setting or the one adjusted by the installer with the following procedure.
- **Warning!** – This function is active with the factory setting but is not applicable if the limit switches are programmed with the manual procedure C.5.
- When performing the procedure, at any time you can cancel it by keeping the and keys pressed simultaneously for 4 seconds. Otherwise, do not press any key and wait 60 seconds for the motor to perform 6 movements.

1		2		3		4		continues →
							Select the desired option and program it as follows →	
Move the awning to a half-way position.	Hold down the button and	count 2 movements	release the button.	Hold down both buttons...	count 2 movements;	release the buttons.		
→ 4				5		end		
<p>4 OPTIONS:</p> <p>x1 = standard sensitivity (*)</p> <p>x2 = minimum sensitivity</p> <p>x3 = medium sensitivity</p> <p>x5 = function deactivated</p>		<p>10 SEC.</p>	<p>1/ 2/ 3/ 5/</p>					
Press and release the button the number of times indicated in the option you have chosen;		after about 10 seconds, the motor performs a number of movements equal to the number of pulses entered.		Hold down the button and	count 3 movements;	release the button.		

(*) = Factory setting.

C C.10 - "FRT" Function: automatic tensioning of the canvas when opening awnings that are not fitted with a mechanism to lock the awning when opening



- This function is useful to eliminate the unsightly depression of the canvas that may form when the awning is open. It is activated by programming position "2" near the limit switch "1". The function may only be used in awnings that DO NOT have any mechanism to lock the canvas in the open position. When the function is activated, when using the automation, the awning lowers to the lower limit switch "1" and then automatically raises to position "2" (the one programmed with the following procedure), stretching the canvas. The function also acts when a partial opening/closing manoeuvre is commanded. In these cases the awning stops in correspondence to the height "H" programmed and then rises automatically until the canvas is taut.

NOTES AND WARNINGS

- The "FRT" function may be programmed exclusively after having programmed the limit switch heights "0" and "1".
- Position "2" must be a point between limit switch "1" and limit switch "0".

1		2			→ 3	
 1 sec.		 5 sec.				
Hold down the button and		Hold down the button and	count 2 movements		release the button.	
3			4			→ 5
 5 sec.			 5 sec.			
Hold down the button and	count 3 movements	release the button.	Hold down the button and	count 4 movements	release the button.	
5		6			end	
	 5 sec.					
The position with the canvas taut is position "2".	Hold down the button and	count 3 movements		release the button.		

C C.11 - Programming the movement (Ascent or Descent) that the motor must perform automatically when it starts to rain (ref. paragraph 6.1.2)



NOTES AND WARNINGS

- When performing the procedure, at any time you can cancel it by keeping the **■** and **▼** keys pressed simultaneously for 4 seconds. Otherwise, do not press any key and wait 60 seconds for the motor to perform 6 movements.

1		2		3 → 4		
Move the awning to a half-way position.	Hold down the button and	count 2 movements	release the button.	Hold down the button and	count 3 movements	release the button.

4		5 ...	
			Programme the movement that the motor must perform automatically when it starts to rain, by selecting one of the following option: • option A – to programme the Raising of the awning. • option B – to programme the Lowering of the awning.
Hold down the button and	count 2 movements	release the button.	

option – A	5		end
	Hold down the button and	count 3 movements	release the button.

option – B	5		end
	Hold down the button and	count 3 movements	release the button.

5 WARNINGS FOR ORDINARY USE OF THE MECHANISM

5.1 - Maximum continuous work cycle

In general, the motors in the "NEXT" line were designed for residential use and therefore for discontinuous use. The motor is designed for residential use, in other words, for intermittent service. In case of extended use, the system limits the motor speed (to the minimum speed) to protect the motor against excessive overheating; in this way, the continuous usage time increases, allowing extended use until the thermal protection device intervenes.

5.2 - Commanding partial opening/closing of the awning

The table shown below summarises the keys to be pressed on the transmitter to send the main opening/closing commands of the awning. These functions are described in detail in the following paragraphs.

Key to be pressed to send the command	Motor action
▲ (UP)	Positioning at the position relative to the UP limit switch
▼ (DOWN)	Positioning at the position relative to the DOWN limit switch
■ (STOP)	Stops the movement
i	Provides feedback on the position
SLIDER (FAST TOUCH)	Change of position
SLIDER + (3 sec)	Increases the motor speed (the motor confirms that the command has been received with a brief movement)
SLIDER ◦ (3 sec)	Normal motor speed (the motor confirms that the command has been received with a brief movement)
SLIDER - (3 sec)	Decreases the motor speed (the motor confirms that the command has been received with a brief movement)
▲ (UP) + ■ (STOP)	Positioning at 90% of the path completed before the 0-UPPER limit switch is reached
■ (STOP) + ▼ (DOWN)	Positioning at 10% of the path completed before the 0-UPPER limit switch is reached
▲ (UP) + ▼ (DOWN)	Positioning at 50% of the path (first pre-set position H)

5.2.1 - Commanding the "H" position

In general, to command the partial opening/closing of the awning (or shutter), press the key associated with the partial height during programming (for more information, read the procedure **B.5**, **A.5** or **C.8**). If the transmitter has only three keys and only one "H" height is memorised, simultaneously press keys ▲ and ▼ to recall this height. If, during the installation phase, the "H" position was not programmed, it will assume the factory value corresponding to the point located between the UPPER and LOWER limit switches.

5.2.2 - Commanding the "90%" and "10%" positions

Two additional partial positions are available (fig. 5), factory-set to the following values:

- "90%" position = 90% of the path completed before the 0-UPPER limit switch is reached (90% of the awning rolled up);
- "10%" position = 10% of the path completed before the 0-UPPER limit switch is reached (10% of the awning rolled up).

To recall the "90%" position, press buttons ▲+■ (UP + STOP).

To recall the "10%" position, press buttons ▼+■ (DOWN + STOP).

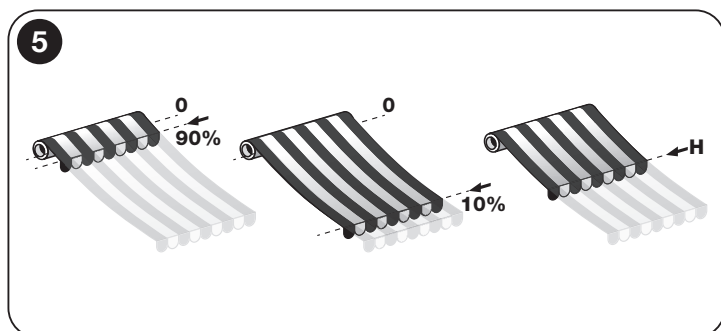

5.3 - The user can vary the awning position with a transmitter equipped with a "slider" surface

It is equally important to be able to set the automation's stop position in relation to the circumstances (sunshine, rain, etc.).

If the automation is controlled with a Nice transmitter equipped with a "slider" surface (e.g. P1V, etc.), the stop position of the automation can be varied as follows: the top of the "slider" moves the automation upwards (as far as the upper limit switch position); the bottom of the "slider" moves the automation downwards (as far as the lower limit switch).

5.4 - "Automatic limit switch update" function

Caution! – This function is only available if the limit switches have been programmed with the Semi-automatic procedure (paragraph **B.4**, **A.4** or **C.7**). This function cannot be disabled.

Periodically the function activates automatically during an up manoeuvre: the awning impacts against the box or other mechanical stop updating the position of the limit switch (Up "0" limit switch). Over time, this compensates for deformations in the structure due to wear and thermal cycles, so that the awning always stops precisely at the Up limit position.

6 OPTIONAL ACCESSORIES

6.1 - Climate sensors for wind, sun, rain

WARNING! – The climate sensors must not be considered safety devices capable of eliminating failures in the awning caused by rain or strong wind; in fact a mere power outage will prevent the awning from moving. Consequently, these sensors must be considered components of an automation device for protecting the awning. The manufacturer declines all liability for any material damages caused by atmospheric events not detected by the sensors.



Key to be pressed	Action
▲ (UP) + ☼ (SUN)	Pressing the keys to enables the receipt by the automation of automatic commands transmitted by any weather sensors fitted on the system.
▼ (DOWN) + ☼ (SUN)	Pressing the keys to disables the receipt by the automation of automatic commands transmitted by any weather sensors fitted on the system.
☼ (SUN)	Provides information on the sensor's enabling status.

6.1.1 - Definitions and conventions

- **Manual "Sun On" Command** = enables reception, by the motor, of automatic commands transmitted by the "Sun" sensor if present in the installation. When reception is enabled, the user can send manual commands at any time: these override the automatic operation of the automated device.
- **Manual "Sun Off" Command** = disables reception, by the motor, of automatic commands transmitted by the "Sun" sensor if present in the installation. When the reception is disabled, the automated device operates exclusively with the manual commands sent by the user. The "Wind" and "Rain" sensors cannot be disabled because they protect the automated device from these atmospheric phenomena.
- **"Above-threshold" intensity of sun/wind** = condition where the intensity of the atmospheric phenomenon corresponds to high values above the set threshold.
- **"Below-threshold" intensity of sun/wind** = condition where the intensity of the atmospheric phenomenon corresponds to low values below the set threshold.
- **"Wind protection"** = a condition in which the system inhibits all the awning opening commands because of the over threshold wind intensity.
- **"Presence of rain"** = a condition in which the system detects the presence of rain, with respect to the previous condition of "absence of rain".
- **"Manual command"** = UP, DOWN or Stop command sent by the user by means of a transmitter.

6.1.2 - Behaviour of the motor in each kind of weather condition

The climate sensors allow you to automate awning/shutter operation in relation to the current weather conditions.

For all sensors, the actuation setpoints must be programmed on the sensors themselves.

Response of the automation to the Sun sensor (fig. 6)

(note – the following automatic operation of the motor will only happen if it was programmed the close / partial opening "H", otherwise the engine will not move). When the intensity of the sun is over threshold, if the awning is at a point between the "0" limit switch and a partial "H" height, the motor brings the awning to the nearest partial "H" height. On the contrary, if the awning is in other positions, the motor does not move it. When the sun is under threshold, the motor is not moved to the awning.

Response of the automation to the Rain sensor (fig. 7)

The rain sensor recognises two states: "absence of rain" and "presence of rain". When the motor receives the message "presence of rain", it automatically activates the manoeuvre (Up or Down) that the installer has programmed for this condition(*). The rain sensor is disabled automatically when it detects the absence of rain for at least 15 minutes.

(*) - If it starts to rain, the system automatically commands the awning to be raised (factory setting). To change this setting, to perform the procedure **A.9**, **B.10** or **C.11**. The automatic rain function is deactivated after the absence of rain has been verified for at least 15 minutes. In this case, the manual commands are always active

and are in addition to the automatically-generated command. If a manual command is sent that is contrary to the previous automatic command, the system carries out the manual command and at the same time starts a 15 minute timer that regenerates the programmed automatic command once this time elapses (e.g. the closure of the awning).

Example: 1) The awning is open. 2) It starts raining. 3) The awning closes. 4) The user forces it to open after a few moments. 5) The awning opens again. 6) 15 minutes after being opened, the awning closes again automatically. 7) It stops raining for at least 15 minutes. 8) The user again opens the awning. 9) The awning remains open.

Response of the automation to the Wind sensor (fig. 8)

When the intensity of the wind exceeds the set threshold, the system activates the wind protection and automatically raises the awning. With the wind protection activated, the manual commands are deactivated and it is not possible to lower the awning. If a command is sent, the automation makes two short movements to signal the intervention of protection.

At the end of the barring period, the manual commands are reactivated and after 10 minutes, automatic operation is restored.

For motors configured in TWO-WAY communications mode, in the event of a malfunction of the climate sensor (low batteries or failure) the motor will make:

- 4 short movements if it receives no feedback from the sensor for too long a period;
- 4 short movements when a command is sent, before executing the requested command.

Generalities:

The automatic operation of the motor by means of the commands received by the climate sensors does not block the manual commands sent by the user of the awning.

- "Rain present" and "wind over threshold" conditions inhibit the operation of the sun sensor.
- The manual command "Sun-ON" enables ("Sun-OFF" disables) only the operation of the Sun sensor.
- The manual commands Raise, Stop, Lower and Partial Opening sent by the user to the motor do not deactivate the operation of the Sun Wind or Rain sensors unless the command completely closes the awning.
- When the awning is completely closed, no climate sensor is able to open it in automatic mode.

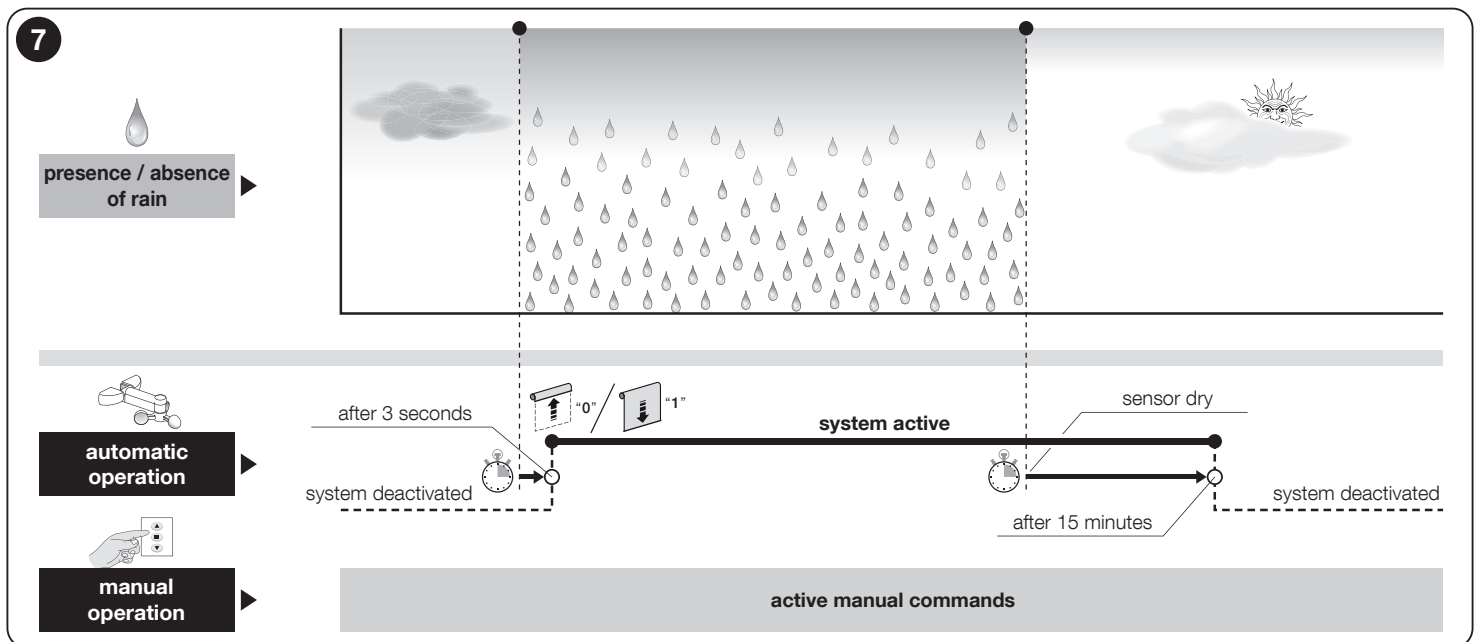
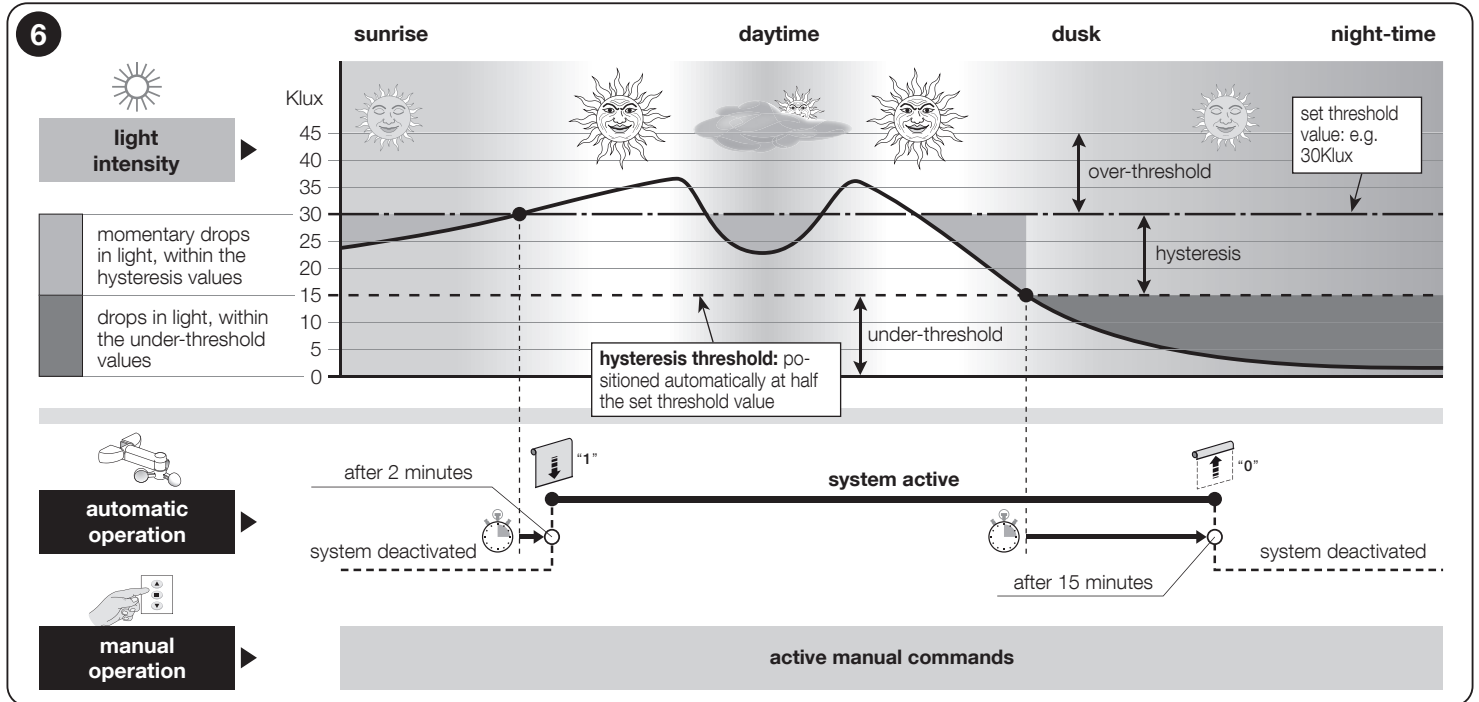

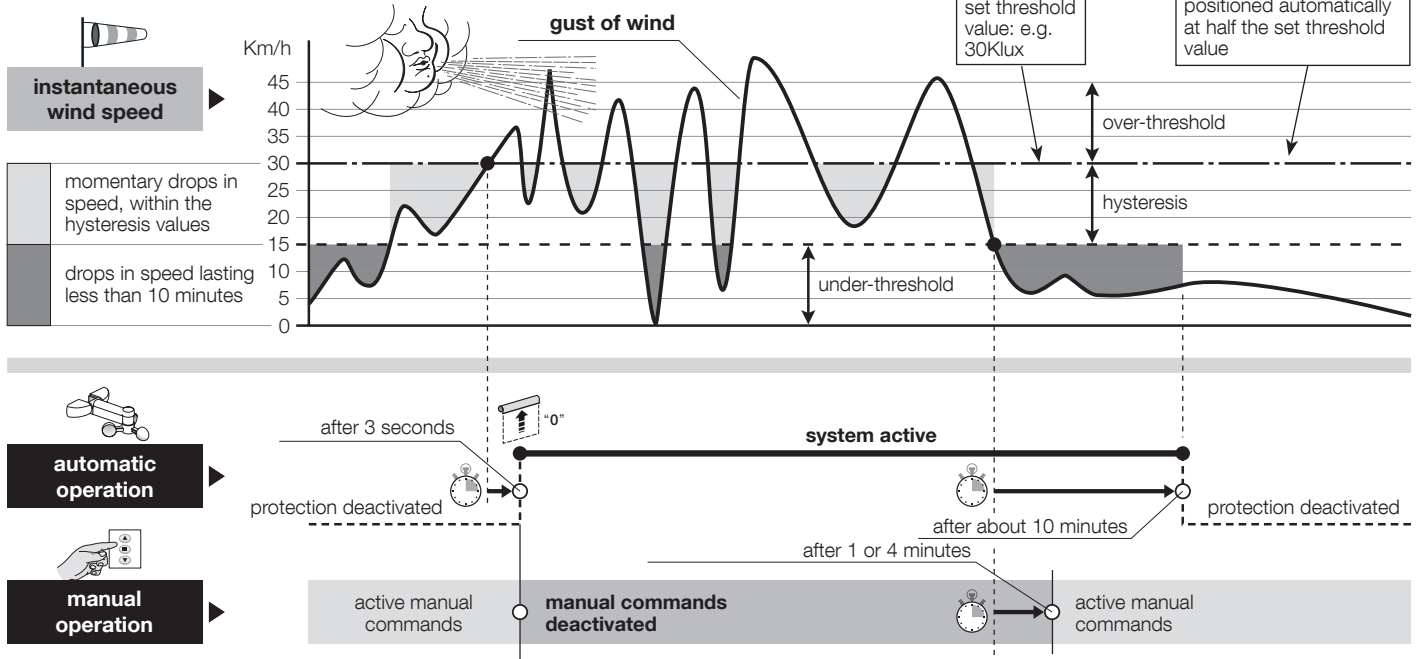

What to do if... (troubleshooting guide)

- ❑ **Powering an electrical phase, the motor does not move:**
After excluding the possibility that thermal protection is active, in which case it is sufficient to wait for the motor to cool down, make sure the mains voltage corresponds to the values indicated in the technical characteristics of this manual by measuring the electricity between the "common" wire and the electrical phase wire supplied with current. Finally, try to supply the opposite electrical phase.
- ❑ **When sending a Raise command, the motor does not start:**
This can happen if the awning is near the Upper limit switch ("0"). In this case you must lower the awning a little bit and give the Raise command again.
- ❑ **The system operates in the emergency condition with an operator present:**
 - Check to see if the motor has undergone a significant thermal or mechanical shock.
 - Make sure each part of the motor is still in good condition.
 - Perform the deletion procedure (procedure **B.12**, **A.11** or **C.4**) and adjust the limit switches again.

Disposal of the product

As in installation operations, disposal operations must be performed by qualified personnel at the end of the product's lifespan.

The product is made of various types of materials: some of them may be recycled, while others must be scrapped. Find out about recycling and disposal systems in use in your area for this product category.

Warning! – Some parts of the product may contain polluting or hazardous substances which, if released to the environment, may cause serious damage to the environment or to human health.

As indicated by the symbol appearing here, the product may not be disposed of with other household wastes. Separate the waste into categories for disposal, according to the methods established by current legislation in your area, or return the product to the retailer when purchasing a new version.

Warning! – Local legislation may impose heavy fines in the event of legal disposal of this product.

The product's packaging materials must be disposed of in full compliance with local regulations.



Technical Characteristics

■ Frequency 433.92 MHz ■ Power emitted: 0 dBm ■ Radio coding: "BD".

Refer to the technical characteristics stated on the motor's nameplate.

Note: • All technical specifications stated herein refer to an ambient temperature of 20° C (± 5° C). • Nice S.p.A. reserves the right to apply modifications to products at any time when deemed necessary, maintaining the same intended use and functionality.

Simplified EU declaration of conformity

Hereby, NICE S.p.A., declares that the radio equipment type NX FIT MT AUTOTRQ 3017 SH BD, is in compliance with Directive 2014/53/EU.

The full text of the EU declaration of conformity is available at the following internet address: <https://www.niceforyou.com/en/support>.

COMPLIANCE WITH THE FCC RULES (PART 15) AND RSS-210 RULES

This device complies with Industry Canada's licence-exempt RSS-210s, and with Part 15 of the FCC rules of the United States of America. Operation is subject to the following two conditions: (1) this device may not cause interference; (2) this device must accept any interference, including interference that may cause undesired operation of the device. Any changes or modifications made to this device, without the express permission of the manufacturer, may void the user's authority to operate this device.



Nice SpA
Oderzo TV Italia
info@niceforyou.com

www.niceforyou.com